



Model 68TM-50 Dual Column Table Model



Preinstallation Manual

M10-17419-EN Revision E

Proprietary Rights Notice

This document and the information that it contains are the property of Illinois Tool Works Inc. (ITW). Rights to duplicate or otherwise copy this document and rights to disclose the document and the information that it contains to others and the right to use the information contained therein may be acquired only by written permission signed by a duly authorized officer of ITW.

Trademarks

Instron® is a registered trademark of Illinois Tool Works Inc. (ITW). Other names, logos, icons and marks identifying Instron products and services referenced herein are trademarks of ITW and may not be used without the prior written permission of ITW.

Other product and company names listed are trademarks or trade names of their respective companies.

Original Instructions

Copyright © 2020 Illinois Tool Works Inc. All rights reserved. All of the specifications shown in this document are subject to change without notice.

Worldwide Headquarters

Instron
825 University Avenue
Norwood, MA 02062-2643
United States of America

European Headquarters

Instron
Coronation Road
High Wycombe, Bucks HP12 3SY
United Kingdom

General Safety Precautions



Materials testing systems are potentially hazardous.

Materials testing involves inherent hazards from high forces, rapid motions, and stored energy. You must be aware of all moving and operating components in the testing system that are potentially hazardous, particularly force actuators or a moving crosshead.

Carefully read all relevant manuals and observe all Warnings and Cautions. The term Warning is used where a hazard may lead to injury or death. The term Caution is used where a hazard may lead to damage to equipment or to loss of data.

Instron products, to the best of its knowledge, comply with various national and international safety standards, in as much as they apply to materials and structural testing. We certify that our products comply with all relevant EU directives (CE mark).

Because of the wide range of applications with which our instruments are used, and over which we have no control, additional protection devices and operating procedures may be necessary due to specific accident prevention regulations, safety regulations, further EEA directives or locally valid regulations. The extent of our delivery regarding protective devices is defined in your initial sales quotation. We are thus free of liability in this respect.

At your request, we will gladly provide advice and quotations for additional safety devices such as protective shielding, warning signs or methods of restricting access to the equipment.

The following pages detail various general warnings that you must heed at all times while using materials testing equipment. You will find more specific Warnings and Cautions in the text whenever a potential hazard exists.

Your best safety precautions are to gain a thorough understanding of the equipment by reading your instruction manuals and to always use good judgement.

It is our strong recommendation that you should carry out your own product safety risk assessment.

Warnings



Hazard - Press the Emergency Stop button whenever you consider that an unsafe condition exists.

The Emergency Stop button removes hydraulic power or electrical drive from the testing system and brings the hazardous elements of the system to a stop as quickly as possible. It does not isolate the system from electrical power, other means are provided to disconnect the electrical supply. Whenever you consider that safety may be compromised, stop the test using the Emergency Stop button. Investigate and resolve the situation that caused the use of the Emergency Stop button before you reset it.



Flying Debris Hazard - Make sure that test specimens are installed correctly in grips or fixtures in order to eliminate stresses that can cause breakage of grip jaws or fixture components.

Incorrect installation of test specimens creates stresses in grip jaws or fixture components that can result in breakage of these components. The high energies involved can cause the broken parts to be projected forcefully some distance from the test area. Install specimens in the center of the grip jaws in line with the load path. Insert specimens into the jaws by at least the amount recommended in your grip documentation. This amount can vary between 66% to 100% insertion depth; refer to supplied instructions for your specific grips. Use any centering and alignment devices provided.



Hazard - Protect electrical cables from damage and inadvertent disconnection.

The loss of controlling and feedback signals that can result from a disconnected or damaged cable causes an open loop condition that may drive the actuator or crosshead rapidly to its extremes of motion. Protect all electrical cables, particularly transducer cables, from damage. Never route cables across the floor without protection, nor suspend cables overhead under excessive strain. Use padding to avoid chafing where cables are routed around corners or through wall openings.

Warnings



High/Low Temperature Hazard - Wear protective clothing when handling equipment at extremes of temperature.

Materials testing is often carried out at non-ambient temperatures using ovens, furnaces or cryogenic chambers. Extreme temperature means an operating temperature exceeding 60 °C (140 °F) or below 0 °C (32 °F). You must use protective clothing, such as gloves, when handling equipment at these temperatures. Display a warning notice concerning low or high temperature operation whenever temperature control equipment is in use. You should note that the hazard from extreme temperature can extend beyond the immediate area of the test.



Crush Hazard - Take care when installing or removing a specimen, assembly, structure, or load string component.

Installation or removal of a specimen, assembly, structure, or load string component involves working inside the hazard area between the grips or fixtures. When working in this area, ensure that other personnel cannot operate any of the system controls. Keep clear of the jaws of a grip or fixture at all times. Keep clear of the hazard area between the grips or fixtures during actuator or crosshead movement. Ensure that all actuator or crosshead movements necessary for installation or removal are slow and, where possible, at a low force setting.



Hazard - Do not place a testing system off-line from computer control without first ensuring that no actuator or crosshead movement will occur upon transfer to manual control.

The actuator or crosshead will immediately respond to manual control settings when the system is placed off-line from computer control. Before transferring to manual control, make sure that the control settings are such that unexpected actuator or crosshead movement cannot occur.



Robotic Motion Hazard - Keep clear of the operating envelope of a robotic device unless the device is de-activated.

The robot in an automated testing system presents a hazard because its movements are hard to predict. The robot can go instantly from a waiting state to high speed operation in several axes of motion. During system operation, keep away from the operating envelope of the robot. De-activate the robot before entering the envelope for any purpose, such as reloading the specimen magazine.

Warnings



Hazard - Set the appropriate limits before performing loop tuning or running waveforms or tests.

Operational limits are included within your testing system to suspend motion or shut off the system when upper and/or lower bounds of actuator or crosshead travel, or force or strain, are reached during testing. Correct setting of operational limits by the operator, prior to testing, will reduce the risk of damage to test article and system and associated hazard to the operator.



Electrical Hazard - Disconnect the electrical power supply before removing the covers to electrical equipment.

Disconnect equipment from the electrical power supply before removing any electrical safety covers or replacing fuses. Do not reconnect the power source while the covers are removed. Refit covers as soon as possible.



Rotating Machinery Hazard - Disconnect power supplies before removing the covers to rotating machinery.

Disconnect equipment from all power supplies before removing any cover which gives access to rotating machinery. Do not reconnect any power supply while the covers are removed unless you are specifically instructed to do so in the manual. If the equipment needs to be operated to perform maintenance tasks with the covers removed, ensure that all loose clothing, long hair, etc. is tied back. Refit covers as soon as possible.



Hazard - Shut down the hydraulic power supply and discharge hydraulic pressure before disconnection of any hydraulic fluid coupling.

Do not disconnect any hydraulic coupling without first shutting down the hydraulic power supply and discharging stored pressure to zero. Tie down or otherwise secure all pressurized hoses to prevent movement during system operation and to prevent the hose from whipping about in the event of a rupture.



Hazard - Shut off the supply of compressed gas and discharge residual gas pressure before you disconnect any compressed gas coupling.

Do not release gas connections without first disconnecting the gas supply and discharging any residual pressure to zero.

Warnings



Explosion Hazard - Wear eye protection and use protective shields or screens whenever any possibility exists of a hazard from the failure of a specimen, assembly or structure under test.



Wear eye protection and use protective shields or screens whenever a risk of injury to operators and observers exists from the failure of a test specimen, assembly or structure, particularly where explosive disintegration may occur. Due to the wide range of specimen materials, assemblies or structures that may be tested, any hazard resulting from the failure of a test specimen, assembly or structure is entirely the responsibility of the owner and the user of the equipment.



Hazard - Ensure components of the load string are correctly pre-loaded to minimize the risk of fatigue failure.

Dynamic systems, especially where load reversals through zero are occurring, are at risk of fatigue cracks developing if components of the load string are not correctly pre-loaded to one another. Apply the specified torque to all load string fasteners and the correct setting to wedge washers or spiral washers. Visually inspect highly stressed components such as grips and threaded adapters prior to every fatigue test for signs of wear or fatigue damage.

Table of Contents

Chapter 1: Introduction	13
System Description and Terminology	14
Components	17
Principle of Operation.....	18
Hardware Controls	18
Software	19
System Safety and Information Labeling	19
Product Support	21
Product Documentation	22
Chapter 2: Requirements	23
Responsibilities.....	23
Customer’s responsibilities	23
Supplier’s responsibilities	24
Site requirements.....	25
Frame location	26
Table requirements.....	26
Floor loading.....	26
Power supply.....	27
Telephone and network access	27
Ceiling clearance	27
Environmental conditions.....	27
Accessibility.....	28
Site requirements for system accessories	28
Environmental specifications.....	29
General	29
Conformity with EU directives	29
Environmental impact.....	30
Noise levels.....	30
68TM-50 Power Requirements and Cords	31

Power requirements	31
Power cord selections	31
Checklist for site preparation	33
Site location	33
Transporting	34
Scheduling installation	35
Chapter 3: Specifications	37
68TM-50 Dimensions and Weight	37
Frame Dimensions	37
System weight	42
Accessory Mounting Dimensions	42
Base beam dimensions	43
Crosshead dimensions	43
Top plate dimensions	44
System Performance	45
Chapter 4: Risk reduction and safe use	47
Residual risks	47
Rapid crosshead motion	48
Pinching fingers between grip jaw faces	50
Impact of debris from breaking specimens	51
Collision Mitigation	52
Ingress Protection	53
Solid particle ingress	53
Liquid ingress	53
Operator Protection Overview	54
Chapter 5: Lifting and handling	57
General handling precautions	57
68TM-50 Packaging dimensions and weight	57
Unpack dual column frames	58
Transport dual column frames	59

Before you begin	60
Equipment	60
Crosshead method	61
Shipping skid method	63
Crane method	65
Level the load frame	66
Secure the frame to the table	68
Procedure	70
Index	73

Chapter 1

Introduction

• System Description and Terminology.....	14
• System Safety and Information Labeling.....	19
• Product Support.....	21
• Product Documentation.....	22

These instructions include the following information:

- system specifications that are required for installation of your testing system, for example required environmental conditions, system weights and dimensions
- transporting your system to its final location, including instructions for lifting and handling
- system performance specifications for this frame model

Refer to the Operator's Guide for instructions on connecting system components, system configuration, running tests, and performing routine maintenance of the system.

System Description and Terminology



Figure 1. 6800 Dual Column Table Model with Bluehill® Operator Dashboard - Front View

Legend for Figure 1

Label	Component
1	T-slots
2	Top plate
3	Column cover
4	Load cell
5	Upper limit switch
6	Limit switch actuator
7	Lower limit switch
8	Emergency stop button
9	Indicator panel
10	Bluehill [®] Operator Dashboard (optional)
11	Handset

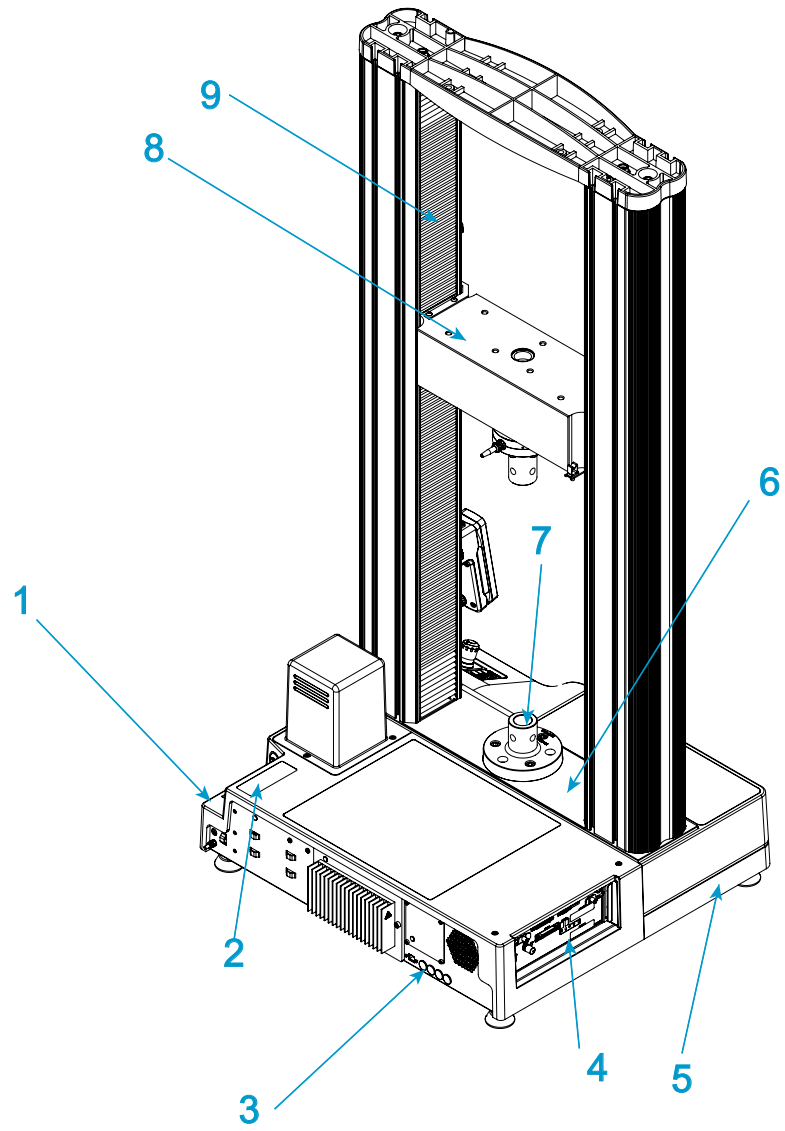

Figure 2. 6800 Dual Column Table Model - Rear View

Legend for Figure 2

Label	Component
1	Power inlet connection and power switch
2	System ID label

Label	Component
3	Rear panel
4	Controller panel
5	Frame base
6	Base beam
7	Base adapter
8	Crosshead
9	Ballscrew cover

Components

The major components of an Instron® electromechanical testing system include:

- Load frame with integral controller
- Load cell mounted to the crosshead
- Grips for tension testing or table-mounted anvils on a platen for compression testing.
- Instron® approved computer system with Instron Bluehill® software.

Special fixtures are available for applications such as flexure and peel testing. For strain measurement, an optional strain gauge extensometer attaches to the specimen. You can use non-contacting extensometers with specimens that are unable to support a contacting extensometer. Contact your regional Instron® office or check our web site at www.instron.com for assistance with Instron’s grips and fixtures.

The following table defines the components of the testing system:

Table 1. Testing System Components

Component	Description
Load Frame	<p>The load frame comprises a base, one or two columns, a moving crosshead, and a top plate. It is a high stiffness support structure against which the test forces react.</p> <p>Each column comprises a guide column and a ballscrew. The crosshead is mounted on both the guide column and the ballscrew. Rotation of the ballscrew drives the crosshead up or down while the guide column provides stability.</p>

Table 1. Testing System Components (Continued)

Component	Description
Controller	The hardware that controls the frame and any ancillary equipment connected to the testing system. The controller panel contains all the connectors for load cells, extensometers and any other sensors that are required for testing.
Indicator Panel	Indicators showing the status of the testing system.
Handset	Holds all of the controls for the testing system.
Load String	Comprises all of the components that you install between the moving crosshead and the load frame base (or fixed crosshead). Typically this involves a load cell, a set of grips, any adapters that are required to connect the components, and the specimen to be tested. Typically, you mount a load cell on the crosshead, then a pair of grips or fixtures on the load cell and frame base. The grips or fixtures secure the specimen and when you start a test the crosshead moves up or down applying a tensile or compressive load to the specimen. The load cell converts this load into an electrical signal that the software measures and displays.
Bluehill [®] Software	Instron [®] testing software that controls the testing system, running tests and analyzing test data to produce test results.
Specimen	A single piece of material to be tested.

Principle of Operation

The system communicates primarily through the controller. The controller contains sensor conditioning cards for the system transducers and transfers data between the transducers and the computer. The controller also communicates with the load frame via a Safety Monitoring Board (SMB) via a Break Out Board (BOB) inside the load frame. The Break Out Board links all the electrical components of the frame together.

Hardware Controls

The hardware controls consist of:

- Emergency stop button - to be used whenever you need to stop the crosshead immediately because an unsafe condition exists.
- Limit stops - these must be set before each test session to protect the operator and load string components against unexpected crosshead movement.
- Indicator panel - indicators showing the status of the testing system.
- Handset - holds all the controls for the testing system.

Software

Control of the testing system is carried out via Instron Bluehill® software. Setting test parameters, operating the system, and collecting test data is done through the software program.

Table 2. Software Terminology

Term	Description
Test Method	In Bluehill® software, a test method is a file that contains a set of defined parameters that the system uses to run tests, analyze the test data, and produce calculated results.
Sample	A group of material specimens, whose properties are studied and compared to gain statistical or quality assurance information. For example, you could take a specimen from different parts of a single manufacturing run of a material to form a sample of the material. The sample is then representative of the complete run and you can test it to ensure that the material quality has remained stable over the complete run. You perform the same test on each specimen in a sample.

System Safety and Information Labeling

Table 3 on page 19 explains the meanings of any safety and information labels that may be attached to any part of the testing system.

Table 3. Safety and Information Labeling Descriptions



Label	Meaning	Purpose
	Electrical hazard	Indicates that an electrical hazard exists from high voltage and/or electrical current.
	Disconnect power supply	Disconnect the power supply before servicing machine.

Table 3. Safety and Information Labeling Descriptions (Continued)







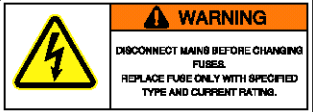

Label	Meaning	Purpose
	Electrical - fuse warning	Indicates an electrical hazard exists. Advises disconnecting power mains before changing fuses and using only specified fuses.
	Belt entanglement hazard	Indicates that a hazard exists from the drive belt and pulley system.
	High temperature hazard	Indicates that a heat hazard exists. Stay clear of area when operating the machine.
	Rotating machinery hazard	Indicates that a rotating hazard exists. Keep clear of these areas (and tie back long hair and loose clothing).
	Ground stud	Indicates a ground stud.
	Read the manual	Read and understand the operator's manual before using the machine.
	Crosshead direction	Indicates the direction to turn the pulley to manually move the crosshead upward. Pulleys can be turned by hand when power is disabled.

Table 3. Safety and Information Labeling Descriptions (Continued)

Label	Meaning	Purpose
 <p>WARNING</p> <p>Crush hazard. Keep clear of test area when machine is in motion. Read and understand operator's manual before using this machine.</p>	Crush hazard	Indicates the crush hazard of the moving crosshead and instructs the user to read and understand the operator's manual before using the machine.
	Waste Electrical and Electronic Equipment (WEEE)	In accordance with the European Union's WEEE directive, the crossed out wheeled bin symbol indicates that the equipment must be disposed of separately from other waste at the end of its usable life. For advice on the disposal of electrical and electronic equipment in your country, contact your local Instron representative.

Product Support

Instron[®] provides documentation, including manuals and online help, that can answer many of the questions you may have. It is recommended that you review the documentation sent with the system you purchased for possible solutions to your questions.

If you cannot find answers in these sources, contact Instron[®] Service directly. A list of Instron[®] offices is available on our website at www.instron.com. In the US and Canada, you can call directly at 1-800-473-7838.

Product Documentation

Instron® offers a comprehensive range of documentation to help you get the most out of your Instron products. Depending on what you have purchased, your documentation may include some or all of the following:

Operator's Guide	How to use your system components and controls, procedures for setting limits, calibration and other frequently performed operating tasks. Information about system installation, set up and configuration, transducer connection and calibration. Routine maintenance and spare parts.
Preinstallation Manual	System requirements and specifications, instructions for lifting and handling to transport the system to its final location before installation.
Reference Help	Software products come complete with context sensitive help, which provides detailed information on how to use all software features.
Equipment Reference	How to set up and use any accessories you have purchased, for example grips, fixtures, extensometers, transducers, and environmental chambers.

We welcome your feedback on any aspect of the product documentation. Please email info_dev@instron.com with your comments.

Chapter 2

Requirements

• Responsibilities	23
• Site requirements	25
• Environmental specifications	29
• 68TM-50 Power Requirements and Cords.	31
• Checklist for site preparation	33

Responsibilities

The responsibilities outlined in this document are general. Refer to your specific purchase contract for full details of your responsibilities and those of Instron®.

Customer's responsibilities

It is the customer's responsibility to ensure that all required support services are available, and that all necessary checks are made prior to installing the testing system. These services and checks are described below.

Site preparation

Proper site preparation is imperative so that the testing system operates in accordance with its specifications and provides accurate test results. The customer must ensure that the site requirements are satisfied prior to scheduling the installation appointment (refer to "[Site requirements](#)" on page 25).

Handling and transporting

Unless specifically arranged otherwise, it is the customer's responsibility to arrange the off-loading, unpacking and moving of the testing system to the final site location (refer to "[Lifting and handling](#)" on page 57).

Upon special arrangements, an Instron[®] service engineer can supervise the off-loading and transportation of the load frame to its final site. Contact Instron[®] Service or your local Instron office for additional information on this service.

Insurance and safety

Under Instron's standard contract, the shipping terms are Ex-Works (or FOB Factory), meaning ownership and liability for the testing system transfers to the customer at Instron's loading dock. Unless other shipping terms are specified in a purchase order, which Instron does not dispute, the Ex-Works shipping terms apply. Under these terms, the customer is responsible for securing the applicable transit insurance on the shipment and arranging safe transport to the final destination. Arrangements can be made through Instron to secure insurance cover and shipping, at the customer's expense.

When transporting a load frame within your own premises, you are responsible for its safe transport. Upon special arrangements, an Instron[®] service engineer can supervise and transportation of the load frame to its final site. Contact Instron[®] Service or your local Instron office for additional information on this service.

Materials disposal

It is the customer's responsibility to properly dispose of any waste materials generated from the installation of the system and its accessories, or from the general operation of the system. This includes packing materials, battery, hydraulic fluid, and waste materials contaminated with hydraulic fluid. Hydraulic fluid is generally considered a hazardous material so proper disposal of this substance, or anything contaminated with it, must comply with local, state, and federal regulations.

Supplier's responsibilities

The standard contract requires Instron[®] to provide the necessary services to ensure that your testing system operates properly. These services are described below.

Additional services and equipment may be negotiated, but these additional services must be mutually agreed upon and specifically described in your purchase order.

Insurance

Under Instron's standard contract, the shipping terms are Ex-Works (or FOB Factory), meaning ownership and liability for the testing system transfers to the customer at Instron's loading dock. Unless other shipping terms are specified in a purchase order, which Instron does not dispute, the Ex-Works shipping terms apply. Under these terms,

Instron is responsible for insurance cover while the testing system is in the factory up until it reaches the loading dock for shipping.

Installation

When the site location is prepared and the frame and its components have been moved to the final operating location (refer to “[Lifting and handling](#)” on page 57), Instron® is responsible for the complete installation of the load frame, its components and any additional accessories that may have been purchased.

The customer must not make any attempt to install the load frame without an Instron® service representative present.

Initial operation

Once the installation is complete, Instron® performs an initial operation of the load frame and a calibration check to ensure that it is working properly.

The service representative also performs a required on-site training program. The required on-site training takes approximately one day to complete, and is designed to accommodate up to three individuals.

Contact Instron® Service for more information on this training. Additional training is available through Instron’s training center.

Documentation

Instron® provides all the documentation required to operate the system, including manuals for the load frame and any required online help systems for software applications.

Additional copies of manuals are available and can be ordered through the Instron® Sales department.

Site requirements

Proper site preparation is imperative so that the testing system operates in accordance with its specifications.

Frame location

Warning



Do not locate the frame directly on the floor.

The testing system is designed to be installed on a table. It should not be located directly on the floor.

The load frame must not be located against a wall or other object that interferes with air ventilation around the frame. Proper air ventilation is required to dissipate the heat generated from the frame base.

Table requirements

The supporting table must be at least 762 mm (30 in) high.

To ensure stability, the spacing of the table legs should be a minimum of 762 mm (30 in) wide and 762 mm (30 in) deep.

The supporting table must be checked for its weight loading and must be able to support the weight of the load frame with all its components and accessories, if the computer and accessories are placed on the same table. There must be a sufficient margin of safety in the table's weight loading to ensure the stability of the system.

The table must be free of vibrations from other activities taking place in or near the building. A table with leveling feet is recommended.

Floor loading

The supporting floor must be checked for its weight loading and be able to support the weight of the load frame and any other accessory parts that may have been purchased. The floor must be free of vibrations from other activities taking place in or near the building.

For larger load frames, it is recommended that you consult your facility engineer, foundation specialist, or a civil engineer to ensure that the load capacity of the floor can support at least three times the weight of the load frame and its component parts. The higher load capacity is necessary because large dynamic loads may occur when a specimen breaks and this additional load may be absorbed into the floor.

Power supply

Ensure that the required power supply is available and complies with all requirements (“[68TM-50 Power Requirements and Cords](#)” on page 31).

Caution

Power fluctuations and surges can cause performance problems ranging from intermittent electrical problems to severe damage.

Instron® systems require “clean” and stable electrical power. Unless other arrangements are made with Instron®, you are responsible for providing clean electrical power. An in-line power surge protector is recommended for all installations.

If you purchased an environmental chamber with your system, it requires a dedicated electrical power supply that is separate from the power supply for the rest of the system.

Telephone and network access

Ensure that a telephone line is located within the general testing area. This enables the user to contact Instron® directly from the testing area so the user can perform the instructions provided and resolve the situation while on the telephone with the service representative. This facilitates resolving issues in a timely manner and reduces the number of repeated phone calls on the same problem.

It is also suggested that network drops, or digital phone lines, be within the general testing area. A network connection near the system facilitates distributing test data via the network. Our goal is to provide remote diagnostics in order to resolve system issues. Having a network drop or digital phone line available will enable an Instron® service representative to connect to the testing system to diagnose and resolve problems more efficiently.

Ceiling clearance

Ensure that there is adequate ceiling clearance so that the load frame can be easily placed in its testing location. Take into consideration how you will be transporting the frame (by forklift or crane, for instance) and ensure that the ceiling height can accommodate your mode of transportation.

Environmental conditions

Ensure that the testing site meets the specifications detailed in “[Environmental specifications](#)” on page 29.

Accessibility

The testing system must be accessible for routine maintenance without having to move the load frame. If the frame is moved, it may need to be re-verified.

Site requirements for system accessories

Some accessories require additional site requirements. If you are not sure if the accessories you purchased require any of the following site preparations, contact Instron[®] Service or your local Instron[®] office for advice.

Compressed air supply requirements

A compressed air supply regulated to a maximum pressure of 8.3 bar (120 psi) is required for the integrated air kit. The regulated supply pressure must be greater than the test pressure value set in Bluehill[®] software.

To maximize the operational life of the integrated air kit and grips, the air supply must be dry and filtered of any particles larger than 20 µm.

- Dry air can be achieved by installing an air dryer (not supplied) such as an in-line desiccant air dryer.
- Filtered air can be achieved by use of a regulator with an integrated filter assembly (not supplied). This should be located as close to the testing system as is practical. A 20 µm filter is required, but the additional filtration of a 5 µm filter is preferred.

The customer is responsible for adapting the pneumatic connection of the integrated air kit to their supply. Instron[®] provides a 0.25 inch (6.3 mm) outer diameter, 0.125 inch (3.2 mm) inner diameter tube, which can be connected using the included 0.25 inch (6.3 mm) NPT male to push-to-connect fitting or an appropriately sized compression or hose barb fitting.

Water supply

A water supply may be required for some specimen grips and some temperature control systems.

Liquid nitrogen and carbon dioxide

A liquid nitrogen (LN2) or carbon dioxide (CO2) supply may be required for environmental chambers with cooling options.

For carbon dioxide, tank pressure must be approximately 725 psi. It must be in a liquid state when it reaches the valve of the environmental chamber.

For liquid nitrogen, tank pressure must be between 5 and 10 psi, depending upon the regulator and relief valves that are fitted to the dewar flask. Do not exceed 20 psi.

Environmental specifications

General

Table 4. Environmental specifications

Parameter	Specifications
Operating Temperature	+5 °C to +40 °C (+41 °F to +104 °F)
Storage Temperature	-25 °C to +55 °C (-13 °F to +131 °F)
Humidity	10% to 90% (non-condensing)
Ingress Protection (IP) Rating	IP 2X. Protective measures may be required if excessive dust, corrosive fumes, electromagnetic fields or hazardous conditions are encountered.

Conformity with EU directives

Instron[®] declares under our sole responsibility that 68SC and 68TM testing systems are in conformity with all relevant provisions of the following regulations:

- Machinery Directive 2006/42/EC
- EMC Directive 2014/30/EU
- ROHS Directive 2011/65/EU including substances added by amendment 2015/863/EU

Instron[®] testing systems are CE marked. A signed CE declaration of conformity is supplied with each system.

Environmental impact

Instron® materials testing systems and their accessories are designed to produce no adverse environmental impact during normal use as long as they are operated and serviced in accordance with their operating instructions.

Normal care must be taken with service items such as greases and oils needed to operate and maintain the equipment as indicated in their packaging and operating instructions.

These systems comprise mechanical and electronic components that contain potentially environmentally harmful chemicals, such as chromium, chromates, lead and brominated fire retardants. Care must be taken at the end of the equipment's life to ensure its disposal in accordance with local environmental regulations.

Because of the wide range of applications where our instruments are used, Instron has no knowledge of the environmental impact of the customer's test pieces or specimens.

Noise levels

When idle or operating at low speed, the noise output for these load frames is less than 70dB(A). When operating at maximum speed, e.g. jogging or returning the crosshead, the noise output can exceed 70dB(A) but does not exceed 76dB(A).

Noise levels do not include noise from specimen breaks.

The noise values are measured at the ear level of an operator positioned in front of the machine.



The noise level of the entire system depends on your particular system configuration. Refer to the documentation supplied with other system components for information about that component's noise level.

The noise output from equipment used for materials or structures testing is also dependent upon the items under test. Instron recommends that users carry out their own noise level measurements to ensure the continuous safety and comfort of personnel.

68TM-50 Power Requirements and Cords

Power requirements

Table 5. 68TM-50 power requirements

Parameter	Specification
Maximum Power (VA)	1400
Single Phase Voltage (Vac) ($\pm 10\%$)	100, 120, 220, 240
Frequency - Hz	47 to 63
Length of Power Cable - m (ft)	2.44 (8)



For 230 Vac operation, the frame is normally set to 240 V.

Warning



Electrical hazard - to ensure safety and Electromagnetic Compatibility (EMC) the facility's receptacle must be a 3-wire grounded receptacle. The ground must be a low impedance earth ground in accordance with national and/or local regulations.

Warning



You must use RCD (residual-current device), also known as GFCI (Ground Fault Circuit Interruption), protection on all power sources if your testing system includes water or any other fluid.

If your system includes any fluids (e.g. water-cooled grips, BioPuls baths, food testing fixtures), you must use RCD protection on all power sources to protect the operator from fluids that might leak into the load frame electronics.

Power cord selections

If you do not make a choice, Instron® chooses the customary power cord that matches the shipping destination for the system.

Table 6. Power cords







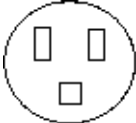

Power cord designation	Matching receptacle	Locale
P1		USA and Canada
P2		Denmark
P3		Europe
P4	<p data-bbox="678 1024 727 1056">and</p>  	Italy
P5		China
P6		Australia and New Zealand
P7		Switzerland

Table 6. Power cords (Continued)

Power cord designation	Matching receptacle	Locale
P8 (includes 10A fuse)		United Kingdom
PA		India and South Africa

Checklist for site preparation

The following checklist provides a quick summary of items that should be considered when planning and preparing the site location of your testing system. Additional information regarding each item below is provided within this manual. If you need more specific information, contact Instron[®] Service or your local Instron[®] office for assistance.

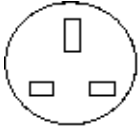
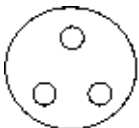

Not all computers are compatible with Instron testing systems. If you intend to purchase a computer from an outside vendor, contact Instron[®] Service to verify its compatibility. Additional charges may result from service that is required to evaluate or reconfigure non-approved computers.

Site location

- Floor and table is able to support the weight of the frame, and its computer components.
- Environment complies with the specifications for your specific model:
 - Operating temperature
 - Storage temperature
 - Humidity
 - Atmosphere
- The required power supply is available and is compatible with the electrical requirements for your specific model.

- Electrical outlets are within the maximum distance requirement to the load frame's location.
- Phone lines are located within the general testing area so that users can call Instron[®] directly from the testing area. It is also suggested that network drops, or digital phone lines, be within the general testing area.
- Ceiling clearance is adequate for the load frame, including the additional space necessary to lift and move the frame by either a forklift or crane.
- Location provides sufficient accessibility for routine maintenance (915 mm (36 in) is recommended).
- Employees are adequately trained to operate the load frame and its computer system.

Transporting

- You have the correct number of packing boxes as stated on the packing list.
- Insurance coverage is secured or verified.
- You have the required equipment for the chosen transporting method.
- You have the appropriate packaging to protect the load frame when moving or relocating it.
- Pathway from the loading dock to the final site location has sufficient width and height to fit the frame and forklift (or crane). Measure all doors and hallways.

Refer to [“68TM-50 Dimensions and Weight”](#) on page 37 for dimensions and weights of the testing system without its packaging. Refer to [“68TM-50 Packaging dimensions and weight”](#) on page 57 for dimensions and weights of the packaged system.

- Floor area along the pathway to the final site location is able to support the weight of the frame and forklift (or crane).

Refer to [“68TM-50 Dimensions and Weight”](#) on page 37 for dimensions and weights of the testing system with and without its packaging. Refer to [“68TM-50 Packaging dimensions and weight”](#) on page 57 for dimensions and weights of the packaged system.

- There are no loose accessories on the shipping skid or frame.
- Your equipment operators have the appropriate licenses and have complied with your local safety standards (i.e. the appropriate training required by OSHA in the U.S.).

Scheduling installation

When the testing site is ready, and the frame has been moved to its final operating location, contact Instron® to schedule an installation appointment.

A list of Instron® offices is available on our website at www.instron.com.

In the United States and Canada, you can call 1-800-473-7838.

Chapter 3

Specifications

- 68TM-50 Dimensions and Weight 37
- Accessory Mounting Dimensions 42
- System Performance 45

68TM-50 Dimensions and Weight

Frame Dimensions

Load frame dimensions for 68TM-50 frames are shown in [Figure 3](#) on page 39 and [Figure 4](#) on page 40.

For those dimensions shown as labels in the figures, [Table 7](#) on page 37 lists them for standard height frames and [Table 8](#) on page 38 lists them for extra height frames.

Dimension “F” in [Figure 3](#) on page 39 varies for different load cells, refer to [Table 9](#) on page 38.

[Figure 5](#) on page 41 shows the overall dimensions of the system including the Bluehill[®] Operator Dashboard.

Table 7. 68TM-50 dimensions - standard height

Letter Designation	Description	Dimension - mm (inch)
A	Overall height	1638 (64.5)
E2	Maximum vertical test space (test daylight - from base to underside of crosshead)	1190 (46.9)
E1	Minimum vertical test space (test daylight - from base to underside of crosshead)	71 (2.8)
B	Overall width	756 (29.8)

Table 7. 68TM-50 dimensions - standard height (Continued)

Letter Designation	Description	Dimension - mm (inch)
D	Horizontal test space (space between columns)	420 (16.5)
J	Crosshead thickness	120 (4.7)
R	Top plate thickness	57 (2.24)
T	Top plate width	180 (7.09)
U	Top plate length	721 (28.4)

Table 8. 68TM-50 dimensions - extra height

Letter Designation	Description	Dimension - mm (inch)
A	Overall height	2163 (85.2)
E2	Maximum vertical test space (test daylight - from base to underside of crosshead)	1695 (66.7)
E1	Minimum vertical test space (test daylight - from base to underside of crosshead)	91 (3.6)
B	Overall width	756 (29.8)
D	Horizontal test space (space between columns)	420 (16.5)
J	Crosshead thickness	120 (4.7)
R	Top plate thickness	57 (2.24)
T	Top plate width	180 (7.09)
U	Top plate length	721 (28.4)

Table 9. Dimension "F" - crosshead to load cell clevis pin hole

Load cell capacity	Connection type	Distance - mm (inch)
500 N, 1 kN, 2 kN	O	91 (3.58)
5 kN	D	101 (3.98)
10 kN, 30 kN, 50 kN	D	122 (4.80)

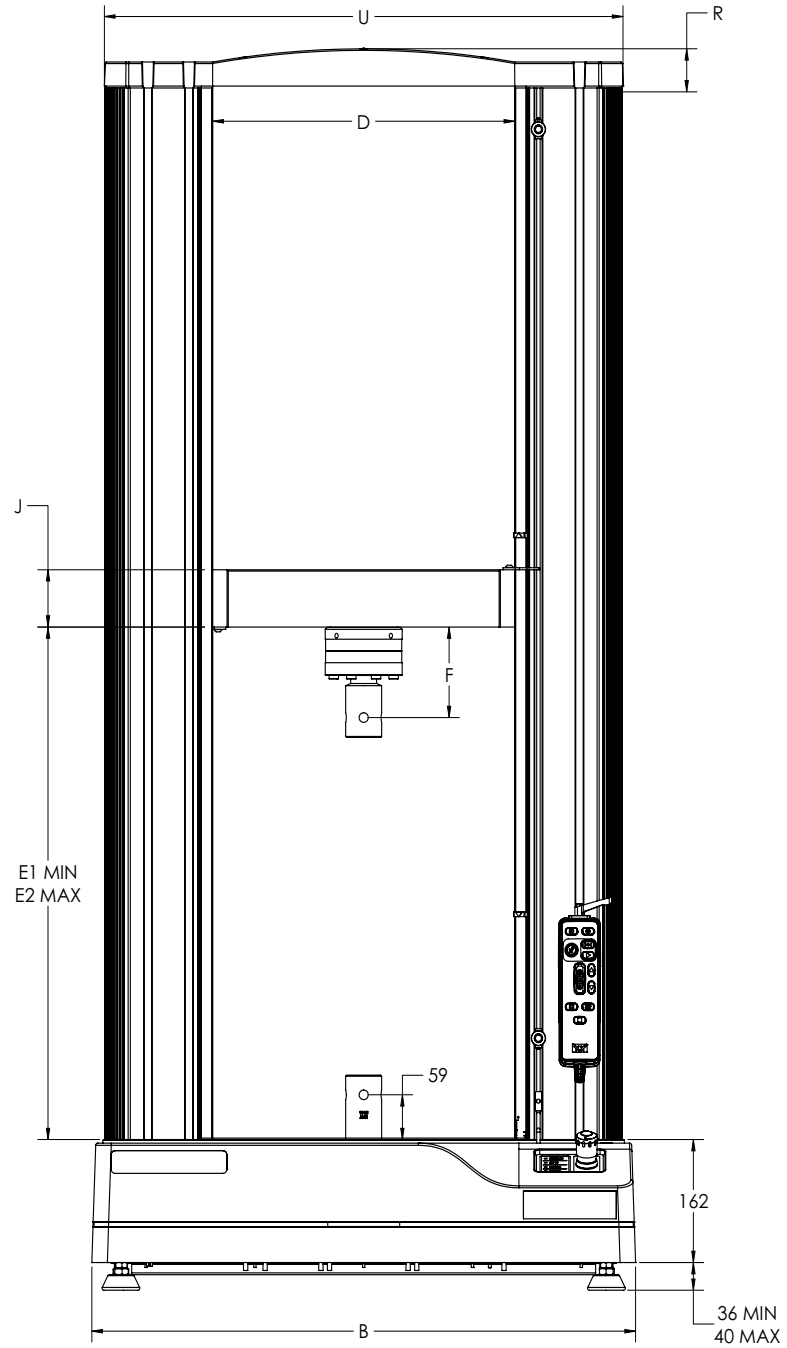

Figure 3. 68TM-50 frame dimensions - front view

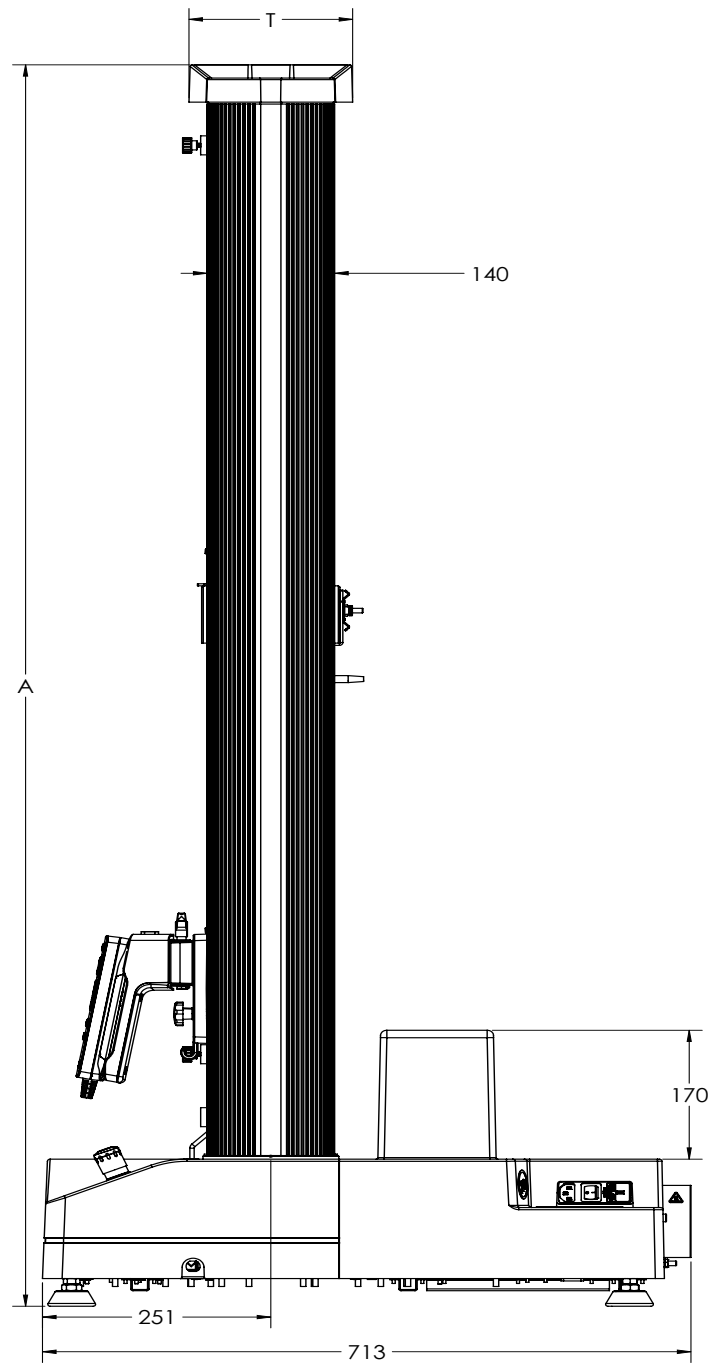

Figure 4. 68TM-50 frame dimensions - side view

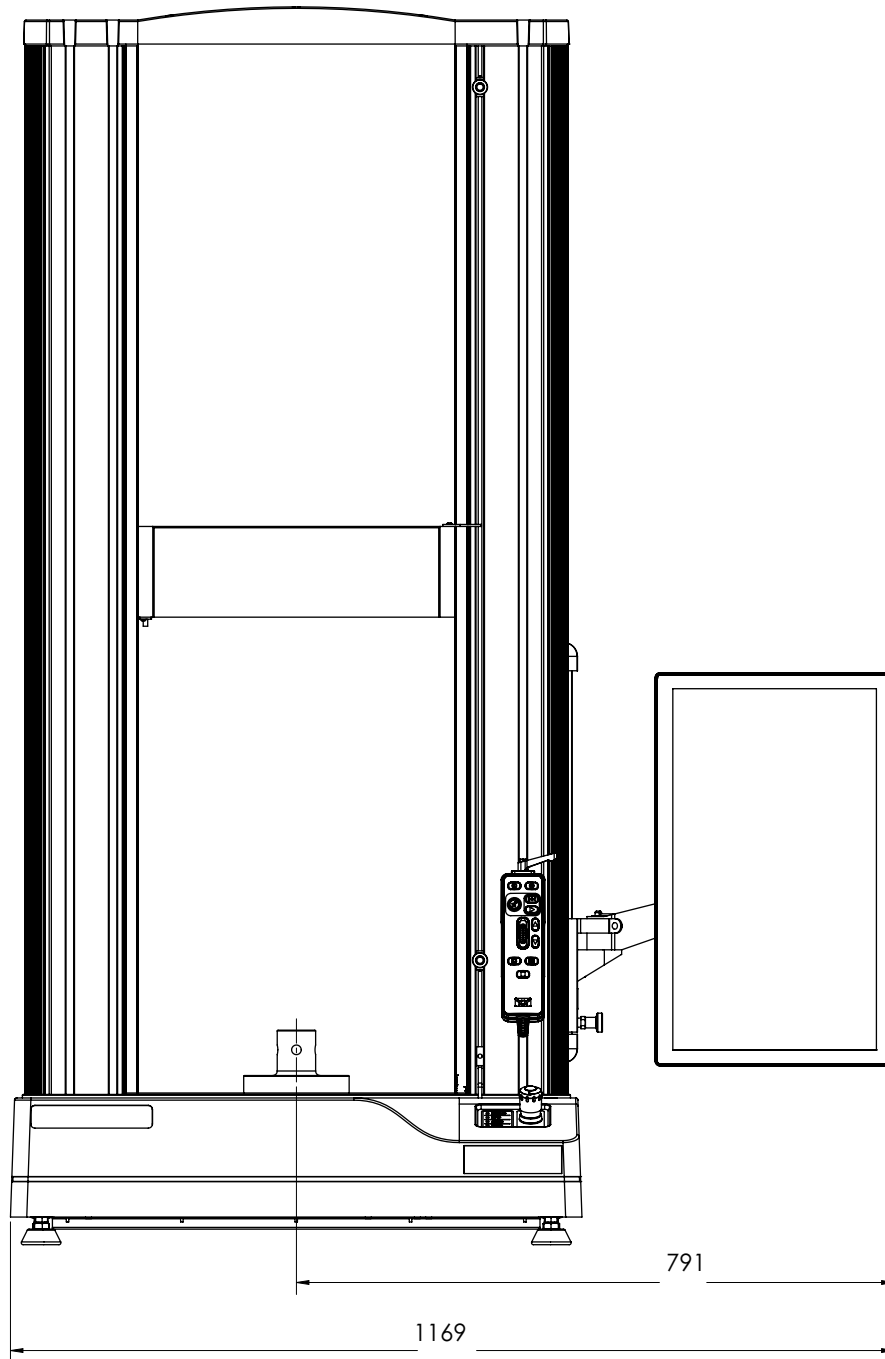

Figure 5. 68TM-50 frame dimensions - including dashboard

System weight

Table 10. System weight

Configuration	Weight kg (lb)
Standard height load frame	254.5 (561)
Extra height load frame	277.6 (612)

The weight value does not include additional accessories such as the Bluehill[®] Operator Dashboard or any load cell.

The weight of the Bluehill[®] Operator Dashboard and its mounting kit is 2.4 kg (5.2 lb).

Accessory Mounting Dimensions

You can attach numerous testing accessories and fixtures to the load frame for specialized tests. Use the standard mounting holes shown in the following diagrams to mount your accessories. Avoid tapping new holes that may weaken or otherwise compromise the integrity of the load frame.



All measurements in the following figures are shown in mm.

Table 11. Meaning of symbols on dimension drawings

Symbol on drawing	Meaning
	diameter
	depth
THRU	through-hole
LH	left hand thread
RH	right hand thread
PCD	pitch circle diameter

Table 11. Meaning of symbols on dimension drawings (Continued)

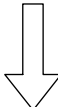
Symbol on drawing	Meaning
	arrow pointing to the front of the load frame

Base beam dimensions

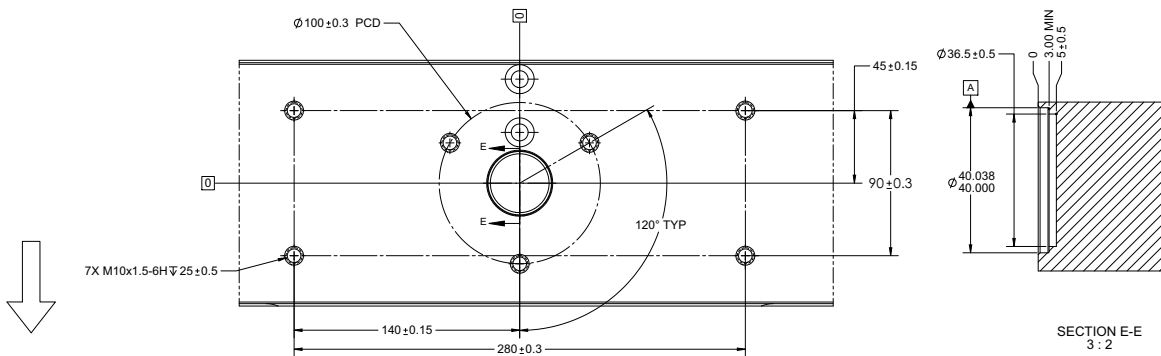

Figure 6. View of base beam from above

Crosshead dimensions

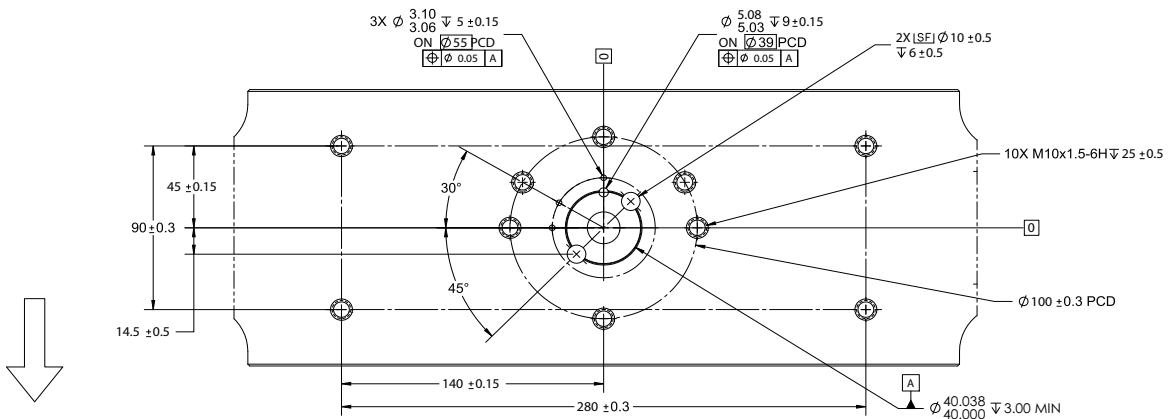

Figure 7. View of underside of crosshead

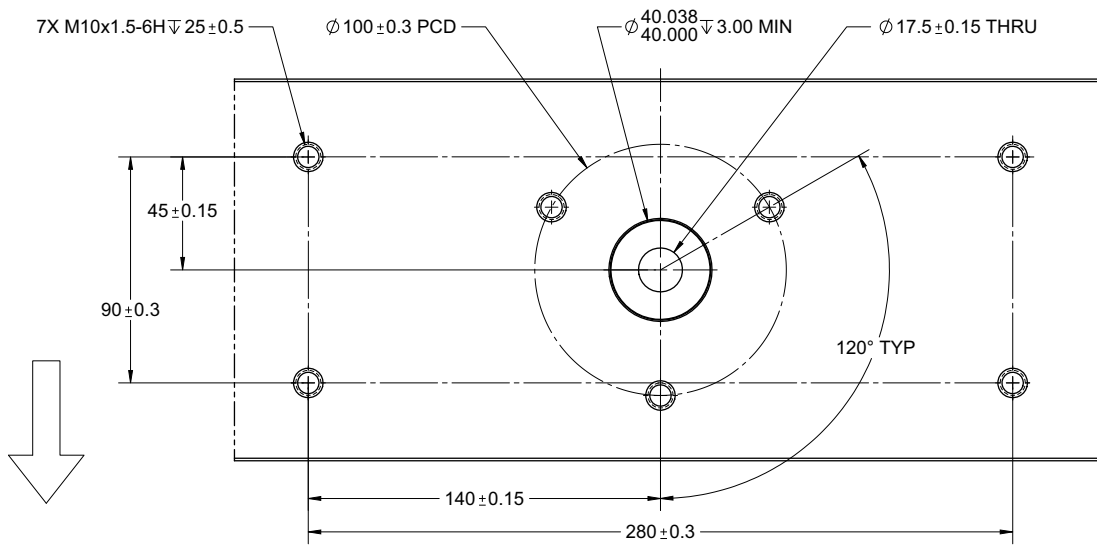

Figure 8. View of top of crosshead

Top plate dimensions

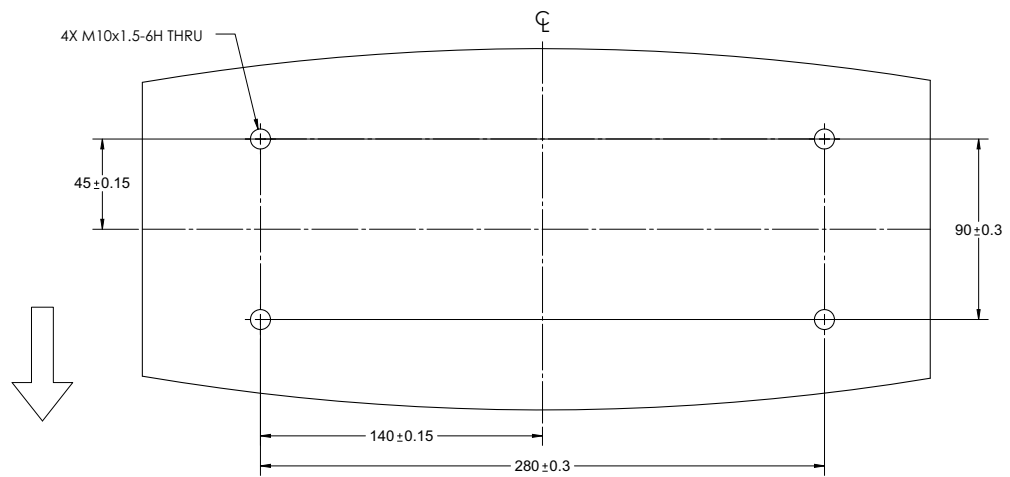

Figure 9. View of underside of top plate

System Performance

Table 12. 68TM-50 system performance

Parameter	Specifications
Testing type	Tension, compression, and through zero operation.
Basic control mode	Closed loop position control
Load capacity - kN (lbf)	50 (11250)
Maximum speed - mm/min (in/min)	762 (30)
Minimum speed - mm/min (in/min)	0.001 (0.00004)
Maximum force at full speed - kN (lbf)	25 (5620)
Maximum speed at full force - mm/min (in/min)	381 (15)
Return speed - mm/min (in/min)	800 (31.5)
Crosshead speed accuracy	$\pm 0.1\%$ of set speed at steady state and no load
Displacement (crosshead position) display accuracy	Under no load conditions, equal or less than ± 0.01 mm (0.0004 in) or $\pm 0.05\%$ of displayed reading, whichever is greater.
Displacement (crosshead position) repeatability - mm (in)	± 0.015 (0.0006)
Load measurement accuracy	$\pm 0.5\%$ of reading down to 1/1000 of load cell capacity.
Strain measurement accuracy	$\pm 0.5\%$ of reading down to 1/50 of full scale with ASTM E83 class B or ISO 9513 class 0.5 extensometer
Crosshead position control resolution - μm	0.00184

Chapter 4

Risk reduction and safe use

• Residual risks	47
• Collision Mitigation	52
• Ingress Protection	53
• Operator Protection Overview	54

This chapter is a copy of a chapter taken from the Operator's Guide that will be supplied with your system. It describes:

- risks associated with use of your testing system
- how to use the features of the testing system to minimize those risks
- accessories that you can purchase to minimize risks if your risk assessment indicates that they are necessary, for example:
 - interlocked shield
 - specimen insertion tool

Residual risks

The equipment described in this documentation is designed with features to reduce the risk of injury to an operator. There are, however, always residual risks in the use of this equipment, influenced by:

- the test application
- the design of the test method or procedure
- the jog, return and test speeds used
- the type of specimen being tested
- the size of the specimen being tested
- the design of grips and test fixtures

- the experience of the operator using the equipment

It is our strong recommendation, therefore, that you carry out your own risk assessment for your particular equipment setup and testing application.

Each of the following sections describes a specific hazard zone of the testing system and lists the most common risks for testing using this equipment. Use the information in the following sections, together with the instructions in the remainder of this manual, to conduct your own risk assessment.

Rapid crosshead motion

Warning



Crush hazard to fingers or hands.

This hazard relates to grips and fixtures coming together as a result of rapid crosshead motion, crushing hands or fingers.

For example, an operator inadvertently commands the system to jog or return while their hands are in test area. This may also happen if the operator, in an attempt to be more efficient, reaches in to remove broken specimen pieces while simultaneously returning the crosshead to zero displacement.

Recommendations

In all situations:

- Set up test methods so that operators do not need to have their hands in the space between fixtures while the crosshead is moving.
- Use the Operator Protection feature in Bluehill® software. This uses a reduced jog speed (default ≤ 600 mm/min) during set up and you can set a lower jog speed if your risk assessment requires it.
- Set appropriate travel limits every time you change the grips and adjust the crosshead.

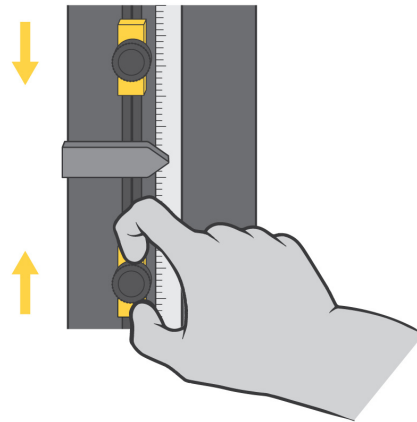

In addition, if the gap between grips and fixtures is less than 50 mm:

- Use a specimen insertion tool and other appropriate equipment and practices to keep fingers out of the space between the fixtures.

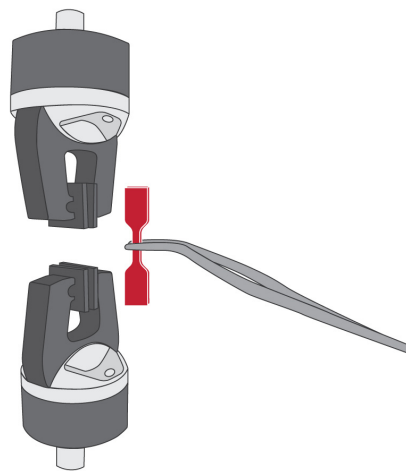

In addition, if the gap between grips and fixtures is less than 25 mm:

- Use a specimen insertion tool to keep fingers out of the space between the fixtures.
- Use an interlocked shield to limit or disallow motion when the shield door is open. When the space is less than 25mm, the crush hazard is very significant, so this is the best option.



Pinching fingers between grip jaw faces

Warning



Pinch hazard to fingers.

This hazard relates to grip jaws closing quickly, pinching fingers.

Recommendations

For 2712 Series pneumatic grips:

- In the documentation supplied with the grips, read and follow the safety recommendations for installing a specimen.
- Use the Operator Protection feature in Bluehill[®] software. This uses a reduced initial grip pressure (default 15 psi) during set up and you can set a lower initial grip pressure if your risk assessment requires it.
- Use jaw face shields.

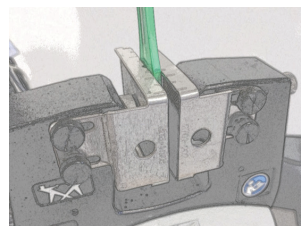

- Use the thumb screw knobs on the sides of the grip (2712-04x grips only) to reduce the jaw face gap to the smallest practical gap for your specimens.

Correct:

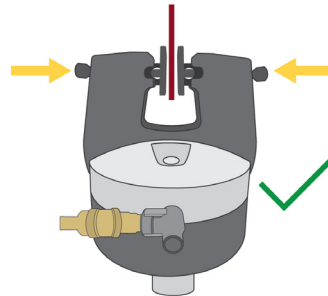

Incorrect:

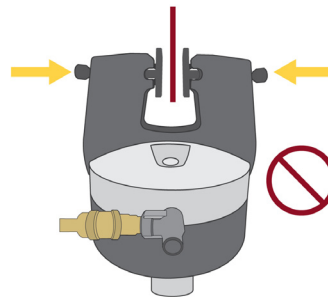

Impact of debris from breaking specimens

Warning



Hazard from flying debris.

This hazard relates to brittle or composite specimens that can explode when they break.

Recommendations

For less dangerous debris (specimen dust or fibers, for example):

- Use personal protection equipment (for example safety glasses).



For more dangerous projectile debris (brittle composite specimens, for example):

- Use an interlocked shield.



Collision Mitigation

The 3400 and 6800 Series systems are equipped with the Collision Mitigation feature to help reduce accidental equipment and specimen damage. Collision Mitigation enables the system to continually monitor force during jog and return operations, and will automatically stop the crosshead movement if an unexpected force is detected.

- When paired with the system's matching capacity load cell, Collision Mitigation can protect the system from colliding with rigid surfaces at speeds up to 600 mm/min.
- Collision Mitigation is intended to mitigate damage to the equipment.
- Collision Mitigation is not safety rated, nor safety intended.

Ingress Protection

To comply with relevant safety and machinery design standards, all aspects of the testing system have been designed to meet an ingress protection rating of at least IP 2X. The testing system is designed for indoor use only, away from wet areas.

The first digit of the ingress protection rating (IP 2_) signifies protection against ingress by solid objects. The number “2” indicates that the design prevents any solid object larger than 12.0 mm from contacting any hazardous internal components (e.g. moving parts, electrical hazards) when all covers and guards are in place.

The second digit of the ingress protection rating (IP _X) signifies protection against ingress by liquids. The letter “X” indicates that ingress protection against liquid is not required to be specified for this application. The testing system is protected only against hazards caused by the incidental spillage of liquids.

Note that in many cases, pragmatic improvements against solid and liquid ingress have been implemented in the design to improve durability and longevity of the testing system.

Solid particle ingress

Solid particles and other debris, particularly conductive or abrasive dust (e.g. metal scale, carbon-based composite fibers) may cause damage to the testing system if allowed to accumulate. If your testing application generates debris, follow these special precautions:

- Clean the testing system and adjacent areas frequently with a vacuum or soft brush to prevent any accumulation of debris.
- As part of periodic maintenance, contact Instron[®] Service to inspect the inside of the testing system for accumulation of debris, and clean it if necessary.
- Clean all outer surfaces thoroughly before performing any service. This prevents debris from falling onto the internal components of the testing system.

Liquid ingress

Any liquid spill onto the testing system may cause equipment damage. Incidental liquid spills will not pose a hazard to the operator if properly addressed.

Take particular care when using any accessory that could spill liquid onto the testing system (e.g. condensation from an environmental chamber, BioBath, or hydraulic accessories).

Instron® sells a variety of accessories, such as drip trays, that can be used to reduce the impact of spilled liquids on your testing system.

If a liquid spill occurs:

1. Discontinue testing immediately and turn off the power to the equipment. Unplug the power cord (if applicable).
2. Clean up as much spilled liquid as possible on the outside of the equipment. Be sure to check underneath rubber mats (if present) and any installed accessories.
3. If you have reason to believe that liquid entered the testing system, contact Instron® Service.
 - a The service engineer will remove the covers of the equipment and clean up all traces of spilled liquid.
 - b Any components damaged by liquid may need to be replaced.
 - c The service engineer will perform an operational check to verify proper function of safety systems.

Warning



Continuing to operate a testing system after liquid has entered the testing system may pose a hazard to the operator and lead to additional equipment damage.

4. Resume testing only after the liquid spill has been properly cleaned up. If the testing system exhibits any faults or unexpected behavior, discontinue testing immediately and contact Instron® Service.

Operator Protection Overview

The majority of hazards for operating materials testing systems are associated with:

- rapid movement of the crosshead causing crush injuries
- rapid closing of pneumatic grips causing pinch injuries

Operator Protection in Bluehill® provides a mechanism that lets you limit crosshead jog speed and reduce grip closing pressure while you are setting up a test.

The default conditions during test set up are:

- crosshead jog speed reduced to a maximum of 600 mm/min, and can be set lower if your risk assessment requires it

- grip closing pressure reduced to a default of 15 psi, and can be set lower if your risk assessment requires it.

Operator Protection lets an Administrator configure the testing system to be consistent with the risk assessment for that system.

Access to the controls for Operator Protection is password protected. If you have Administrator rights you can modify Operator Protection in the Admin tab in Bluehill®.

Chapter 5

Lifting and handling

• General handling precautions	57
• 68TM-50 Packaging dimensions and weight	57
• Unpack dual column frames	58
• Transport dual column frames	59
• Level the load frame	66
• Secure the frame to the table	68

General handling precautions

Only individuals experienced with the operation of lifting equipment and rigging techniques should attempt to lift or move an Instron[®] system. Equipment operators must have the appropriate licenses and have complied with your local safety standards (e.g. the appropriate training required by OSHA in the U.S.).

Always follow the instructions provided with the shipping package. Contact Instron[®] if you require any additional information or if any part of the shipment is damaged.

68TM-50 Packaging dimensions and weight

Instron recommends leaving the load frame in its packaging while moving it to its final site location within your building.

Use the information in [Table 13](#) on page [58](#) to verify that:

- the packaged frame fits through all doorways and hallways leading to the final location
- all floors leading to the final location can support the weight of the packaged frame

Table 13. Packaged dimensions and weights

Configuration	Length mm (in)	Width mm (in)	Height ¹ mm (in)	Packaged weight ² kg (lb)
Standard height	864 (34)	1168 (46)	1905 (75)	255 - 455 (561 - 1000)
Extra height	864 (34)	1168 (46)	2337 (92)	278 - 455 (612 - 1000)

1. This dimension is the maximum height possible. Depending on the contents, the packaging height may be reduced.
2. This value is a range and varies with the number of accessories purchased and shipped with the system.

Unpack dual column frames

Before moving the load frame, review the following sections:

- “[Site requirements](#)” on page 25.
- “[Transport dual column frames](#)” on page 59.

1. Move the load frame, still in the shipping material, to its final location within your building. Use a forklift (or crane) to transport the frame from the shipping dock to the final location. Unpack the load frame after it has been moved to its final location.



After unpacking the load frame, it may be necessary to position the frame into its operating location. Do not remove the wooden skid until you decide which method will be used to move the frame to its operating location. The skid is required if you choose to lift the frame from under the base.

2. Remove the shipping material, leaving the load frame fastened to the shipping skid.
3. Remove the shrink wrap vapor barrier encasing the load frame.
4. Use the packing list to inventory all the boxed items. Some accessories may be in the container with the load frame or may be packaged separately.
 - a Do not open any of the packing boxes until the Instron service engineer arrives to install your testing system. The packing list indicates the total number of boxes that are included in the shipment. Count the number of boxes you received to make sure you have the correct number of boxes. This ensures that no parts are lost prior to installation.
 - b Do not disassemble or remove any components or parts from any Instron frame or accessory.

5. Retain all packing materials until the system is satisfactorily installed and all parts, assemblies and accessories are located.
6. Move the load frame into its operating location using the selected transportation method. Refer to “[Transport dual column frames](#)” on page 59 for additional information.

Transport dual column frames

There are three methods for transporting the load frame to the test site:

- Crosshead method (preferred)- using a forklift with padded forks to lift the load frame from under the crosshead.
- Shipping skid method - using a forklift to lift the load frame from underneath the base with the shipping skid still attached.
- Crane method - using a crane with slings to lift the load frame from the crosshead.

Instron® strongly recommends using professional riggers experienced in moving heavy equipment.

Warnings



Hazard - do not lift the frame by the base.

The base covers cannot support the weight of the frame. If you try to lift the frame with a forklift under the base, the base covers could break and cause personal injury and equipment damage.



Hazard - do not lift the frame by the top plate.

The top plate cannot support the weight of the frame. If you try to lift the frame with a forklift under the top plate, the top plate could break and cause personal injury and equipment damage.



Hazard - always use a lifting device or straps with sufficient capacity to lift the load frame.

You must use a lifting device or straps rated for a capacity at least twice the weight of the load frame.



Hazard - Do not tilt an unsupported load frame more than 10° when it is in the upright position.

Tilting by more than 10° may topple the load frame and cause personal injury and equipment damage.

Before you begin

Before moving the load frame ensure that:

- All site requirements are met (“[Site requirements](#)” on page 25).
- Operators of any lifting equipment have the appropriate licenses and have complied with your local safety standards (e.g. the appropriate training required by OSHA in the U.S.).
- At the final site location, there is adequate clearance between the ceiling and the top of the load frame, including clearance for lifting the frame via a forklift.
- The frame and forklift can fit through all doorways, halls, elevators or stairs from the shipping dock to its final site location.

If the frame is still in its packaging, check the packaging dimensions for your frame model (“[68TM-50 Packaging dimensions and weight](#)” on page 57).

If you are moving the frame without its packaging, check the dimensions for your frame model (“[68TM-50 Dimensions and Weight](#)” on page 37).

- The floors from the shipping dock to the final site location have sufficient support for the weight of the load frame and forklift combined.
- You have adequate packaging materials to protect the load frame when moving it to another site. Contact Instron[®] Service to determine the appropriate packaging requirements for your frame model.
- There are no loose accessories on the shipping skid.

Equipment

- A forklift with a load rating that is double the load frame’s gross weight.
- Protective padding for the crosshead.
- 8 mm wrench for securing bolts for the table top machines.

Warnings



Hazard - do not lift the frame by the base.

The base covers cannot support the weight of the frame. If you try to lift the frame with a forklift under the base, the base covers could break and cause personal injury and equipment damage.



Hazard - do not lift the frame by the top plate.

The top plate cannot support the weight of the frame. If you try to lift the frame with a forklift under the top plate, the top plate could break and cause personal injury and equipment damage.

Crosshead method

This method requires protective padding on either the crosshead or forklift arms to protect the crosshead from scratching or marring.

This method can be used to:

- Transport the load frame to the site location.
- Lift a tabletop load frame onto a table or workbench.
- Lift the frame to remove the transport skid from the frame's base.

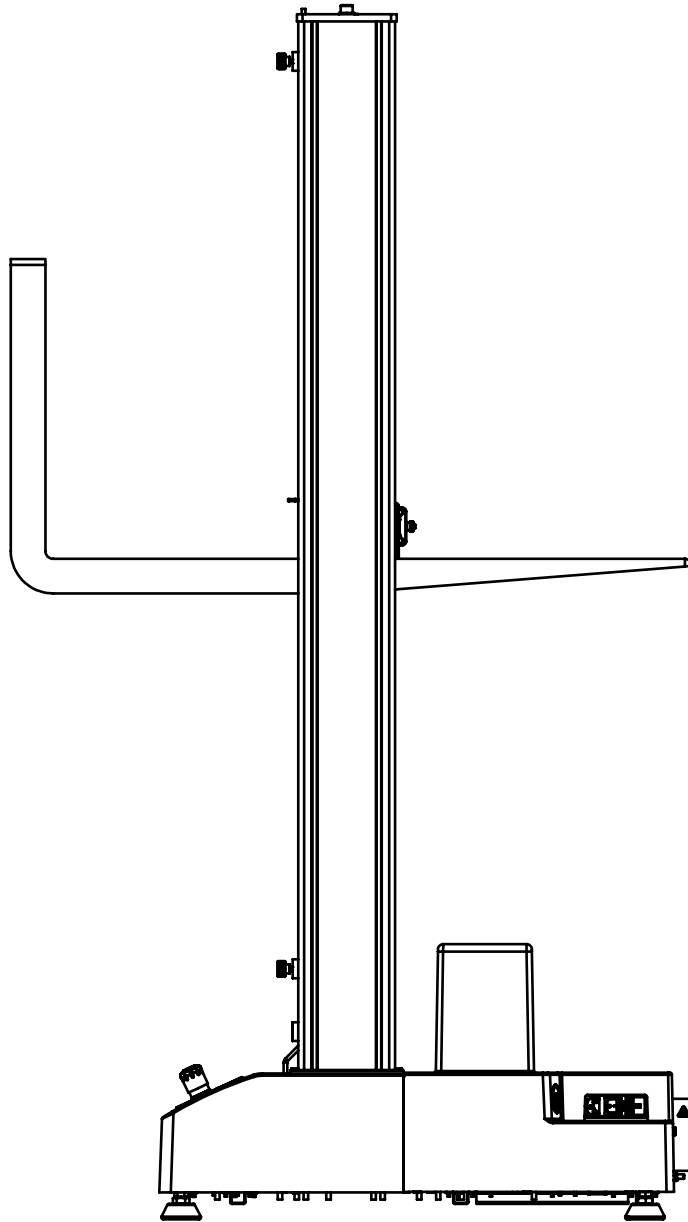

Figure 10. Lifting the Frame from the Crosshead

1. Ensure that there are no shipping bolts attached to the skid.

2. Using a forklift with padded forks or protective material around the crosshead, carefully insert the forks under the crosshead between the columns. See [Figure 10](#) on page [62](#).

Warning



Crush hazard - Ensure that all persons in the immediate area are standing away from the frame during lifting.

Do not lift the frame more than 8 cm (3 in) off the floor.

3. Slowly and carefully lift the frame off the floor.
4. Remove the shipping skid, if it has not already been removed.
5. Move the frame to its operating location.
6. Place the load frame carefully into position.
7. Remove the padded forks from under the frame's crosshead.

When the frame is in its operating location, you can proceed with the installation process.

Shipping skid method

Lifting the frame by this method requires that the base be firmly attached to a shipping skid. The center of the base, where the forklift arms would be placed if no shipping skid was used, cannot support the weight of the load frame.

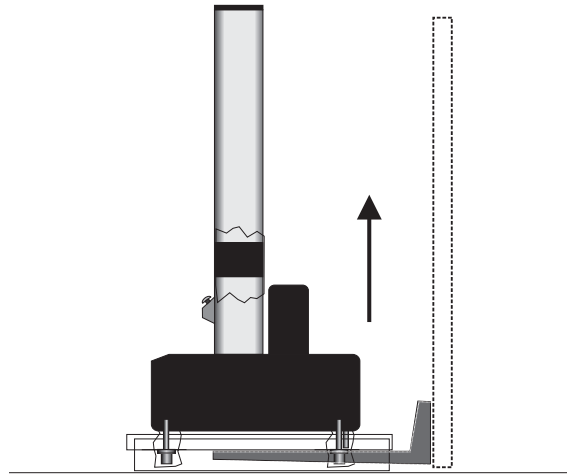

Figure 11. Lifting the Frame using the shipping skid

1. Ensure that the frame is bolted to the shipping skid.
2. Carefully insert the forks under the shipping skid as shown in [Figure 11](#) on page 64.
3. The crosshead should be in its lowest position so that the frame is not top heavy.

Warning



Crush hazard - Ensure that all persons in the immediate area are standing away from the frame during lifting.

Do not lift the frame more than 8 cm (3 in) off the floor.

4. Slowly and carefully lift the frame off the floor.
5. Move the frame to its operating location.
6. Slowly lower the frame to the floor.
7. Before placing the frame in its operating location, you must remove the shipping skid. Follow the instructions described under “[Crosshead method](#)” on page 61 to remove the shipping skid and position the frame.

When the frame is in its operating location, you can proceed with the installation process.

Crane method

Caution

Instron® **STRONGLY** recommends using professional riggers experienced in moving heavy equipment.

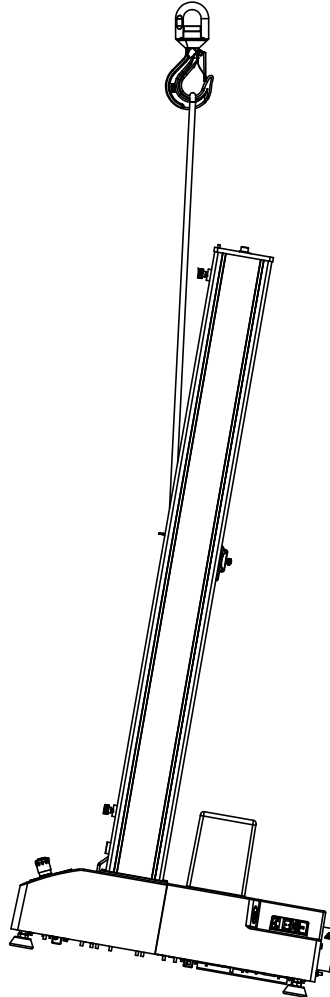

Figure 12. *Lifting Load Frame with a Crane*

1. Attach the lifting sling to the crosshead and secure it to the crane hook such that the sling extends vertically from the FRONT of the crosshead as shown in [Figure 12](#) on page [65](#). If you use chains in lieu of a lifting sling, wrap protective material around the crosshead to protect the crosshead from scratching and marring.

Caution

Ensuring that the sling extends vertically from the front of the crosshead minimizes the risk of damage to the top plate. When the frame is lifted, it will tilt toward the rear.

Warning



Crush hazard - Ensure that all persons in the immediate area are standing away from the frame during lifting.

Do not lift the frame more than 8 cm (3 in) off the floor.

2. Slowly and carefully lift the frame off the floor.
3. Remove the shipping skid, if it has not already been removed.
4. Move the frame to its operating location.
5. Place the load frame carefully into position.
6. Remove the lifting straps from the crosshead, and any protective padding, if used.

When the frame is in its operating location, you can proceed with the installation process.

Level the load frame

Level the load frame immediately after you position it for installation. This prevents the base from rocking and provides a level test surface for more accurate results.

Refer to [Figure 13](#) on page [67](#) and follow the procedure.

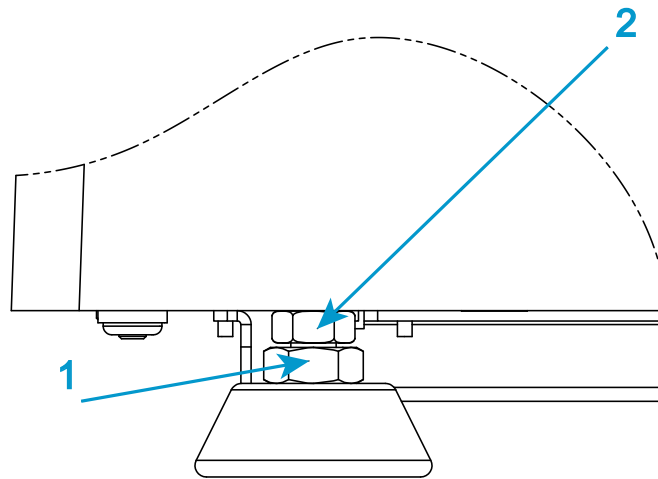

Figure 13. Adjust the leveling feet

You need the following equipment (supplied in the ancillary parts kit unless specified otherwise):

- Spirit level (not supplied)
- 19mm combination wrench (part no. P632-484)
- 16mm thin open-ended wrench (part no. P632-482)

Caution

Make sure that the full weight of the frame is bearing down on the feet. If it is not, you will not be able to adjust the feet.

1. Place a spirit level on the center of the base beam.
2. Use the 19mm wrench to loosen the lock nut (1) on each leveling foot.
3. Use the 16mm thin open-ended wrench to turn the level adjuster nut (2) on each foot while you monitor the spirit level reading.

Warning



As you make adjustments, make sure that no more than 12 mm (0.5 in) of thread is exposed.

If you expose more than 12 mm (0.5 in) of thread, there is a risk that the threaded adapter can separate from the foot.

4. Rotate the spirit level 90 degrees to verify that the load frame is level side to side and front to back.
5. When the machine is level, use the 16mm thin open-ended wrench to hold the level adjuster nut (2) while using the 19mm wrench to tighten the lock nut (1) on each foot.



You have the option to secure the load frame to the supporting table (refer to [“Secure the frame to the table”](#) on page 68).

Secure the frame to the table

You can secure the load frame to the table using the bolt holes in the frame base.

Caution

If your system is located in an area where seismic activity is a concern, securing the system may be required based on local regulations.

You will need the following equipment (not supplied):

- appropriate equipment to drill holes in the table
- torque wrench

You will need the following parts (supplied in available anchoring kit):

- Four M12 x 1.75 bolts
- Four M12 oversized washers



The bolts in the anchoring kit are suitable for table thicknesses between 21 mm (0.83 in) and 49 mm (1.93 in). If your table thickness is outside this range, you will need to provide alternative hardware.

Caution

If you provide alternative hardware, the bolts must not extend more than 40 mm into the frame base as they may cause damage to internal components.

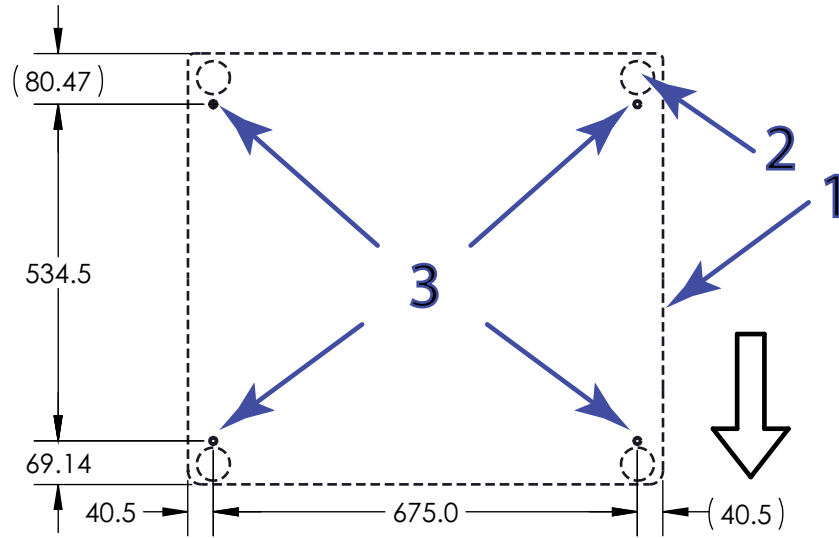
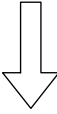

Figure 14. Location of anchoring points (view from above)

Legend for Figure 14

Label	Description
	arrow pointing to the front of the load frame
1	Outline of frame base
2	Outline of frame feet
3	Anchoring points

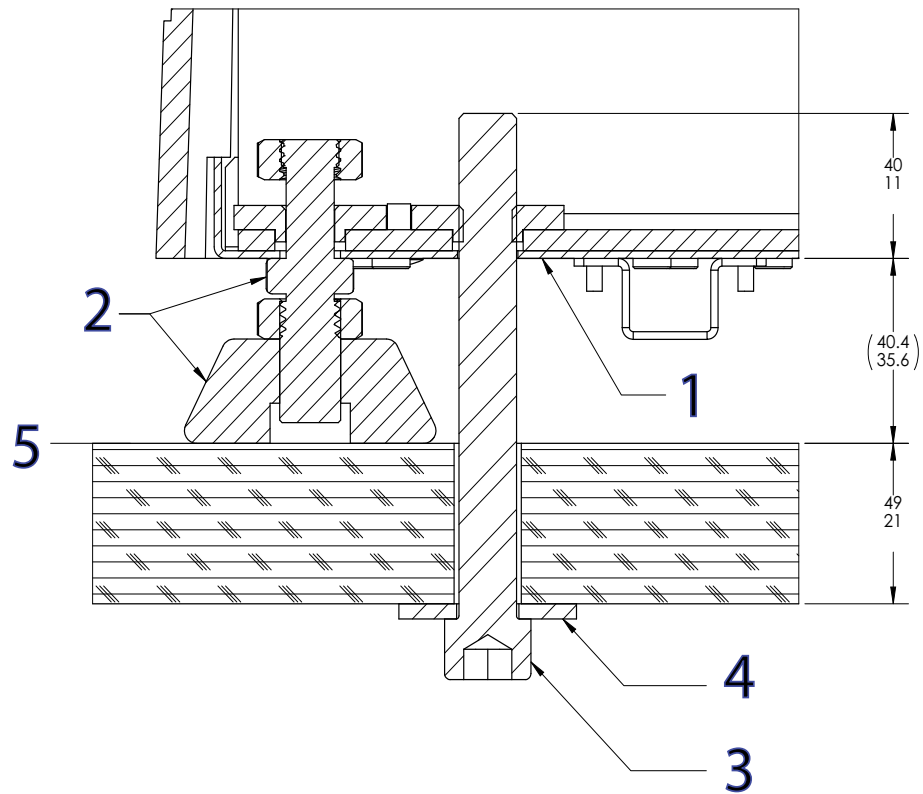

Figure 15. Secure the frame to the table

Legend for Figure 15

Label	Description
1	Frame base
2	Frame foot assembly
3	M12 x 1.75 bolt
4	M12 oversized washer
5	Table surface

Procedure

1. Refer to Figure 14 on page 69 and drill holes in the table at the appropriate locations to align with the anchoring points on the frame base. 15 mm (0.59 in) diameter holes are recommended.

2. Position the testing system over the holes in the table surface. Ensure that the frame is level before proceeding (refer to “[Level the load frame](#)” on page 66).
3. Install each bolt and oversized washer as shown in [Figure 15](#) on page 70.
4. Torque each bolt to 3.2 N-m (0.33 kg-m, 28.3 lb-in).

Caution

Do not overtighten the bolts as this can damage the frame base.

Index

A	
accessibility.	28
accessory mounting dimensions.	42
C	
ceiling clearance.	27
checklist	33
chromium	30
contact information	21
customer responsibilities.	23
D	
digital phone lines	27
dimensions	
accessory mounting	42
dimensions, standard configuration	31
documentation	25
E	
environmental conditions	27
environmental impact	30
F	
floor loading	26
frame	
dimensions, standard configuration	31
I	
impact, environmental	30
initial operation of the system.	25
installation	
Instron's responsibilities.	25
Instron	
contact information.	21
product support.	21
Instron responsibilities.	24
insurance	
customer's responsibilities.	24
Instron's responsibilities.	24
L	
labeling	
safety and information.	19
lead, brominated fire retardants	30
load frame	
dimensions, standard configuration.	31
M	
materials disposal	24
moving, dual column frames	
frame base method	63
moving, frames	
crane method.	65
crosshead method	61
N	
network access	27
noise levels	30
P	
power supply	27
preparation checklist	33
product support.	21
R	
remote system access	27
responsibilities	
customer.	23
Instron.	24
routine maintenance.	28
S	
safety and information labeling	19
site preparation checklist.	33
site requirements	25
specifications	
dimensions.	31
noise levels.	30
support.	21
system performance	45

T

table loading	26
technical support	21
telephone access	27
transporting procedures, frames	
crane method	65
crosshead method	61
frame base method.	63



www.instron.com