

**Model DX Static Hydraulic
Universal Testing System**

System Concepts Manual
M47-17028-EN Revision C

Electromagnetic Compatibility

Where applicable, this equipment is designed to comply with International Electromagnetic Compatibility (EMC) standards.

To ensure reproduction of this EMC performance, connect this equipment to a low impedance ground connection. Typical suitable connections are a ground spike or the steel frame of a building.

Proprietary Rights Notice

This document and the information that it contains are the property of Illinois Tool Works Inc. (ITW). Rights to duplicate or otherwise copy this document and rights to disclose the document and the information that it contains to others and the right to use the information contained therein may be acquired only by written permission signed by a duly authorized officer of ITW.

Trademarks

Instron® is a registered trademark of Illinois Tool Works Inc. (ITW). Other names, logos, icons and marks identifying Instron products and services referenced herein are trademarks of ITW and may not be used without the prior written permission of ITW.

Other product and company names listed are trademarks or trade names of their respective companies.

Original Instructions

Copyright © 2018 Illinois Tool Works Inc. All rights reserved. All of the specifications shown in this document are subject to change without notice.

Corporate Headquarters

Instron
825 University Avenue
Norwood, MA 02062-2643
United States of America

European Headquarters

Instron
Coronation Road
High Wycombe, Bucks HP12
3SY
United Kingdom

General Safety Precautions



Materials testing systems are potentially hazardous.

Materials testing involves inherent hazards from high forces, rapid motions, and stored energy. You must be aware of all moving and operating components in the testing system that are potentially hazardous, particularly force actuators or a moving crosshead.

Carefully read all relevant manuals and observe all Warnings and Cautions. The term Warning is used where a hazard may lead to injury or death. The term Caution is used where a hazard may lead to damage to equipment or to loss of data.

Instron products, to the best of its knowledge, comply with various national and international safety standards, in as much as they apply to materials and structural testing. We certify that our products comply with all relevant EU directives (CE mark).

Because of the wide range of applications with which our instruments are used, and over which we have no control, additional protection devices and operating procedures may be necessary due to specific accident prevention regulations, safety regulations, further EEA directives or locally valid regulations. The extent of our delivery regarding protective devices is defined in your initial sales quotation. We are thus free of liability in this respect.

At your request, we will gladly provide advice and quotations for additional safety devices such as protective shielding, warning signs or methods of restricting access to the equipment.

The following pages detail various general warnings that you must heed at all times while using materials testing equipment. You will find more specific Warnings and Cautions in the text whenever a potential hazard exists.

Your best safety precautions are to gain a thorough understanding of the equipment by reading your instruction manuals and to always use good judgment.

It is our strong recommendation that you should carry out your own product safety risk assessment.

Warnings



Hazard - Press the Emergency Stop button whenever you consider that an unsafe condition exists.

The Emergency Stop button removes hydraulic power or electrical drive from the testing system and brings the hazardous elements of the system to a stop as quickly as possible. It does not isolate the system from electrical power, other means are provided to disconnect the electrical supply. Whenever you consider that safety may be compromised, stop the test using the Emergency Stop button. Investigate and resolve the situation that caused the use of the Emergency Stop button before you reset it.



Flying Debris Hazard - Make sure that test specimens are installed correctly in grips or fixtures in order to eliminate stresses that can cause breakage of grip jaws or fixture components.

Incorrect installation of test specimens creates stresses in grip jaws or fixture components that can result in breakage of these components. The high energies involved can cause the broken parts to be projected forcefully some distance from the test area. Install specimens in the center of the grip jaws in line with the load path. Insert specimens into the jaws by at least the amount recommended in your grip documentation. This amount can vary between 66% to 100% insertion depth; refer to supplied instructions for your specific grips. Use any centering and alignment devices provided.



Hazard - Protect electrical cables from damage and inadvertent disconnection.

The loss of controlling and feedback signals that can result from a disconnected or damaged cable causes an open loop condition that may drive the actuator or crosshead rapidly to its extremes of motion. Protect all electrical cables, particularly transducer cables, from damage. Never route cables across the floor without protection, nor suspend cables overhead under excessive strain. Use padding to avoid chafing where cables are routed around corners or through wall openings.



High/Low Temperature Hazard - Wear protective clothing when handling equipment at extremes of temperature.

Materials testing is often carried out at non-ambient temperatures using ovens, furnaces or cryogenic chambers. Extreme temperature means an operating temperature exceeding 60 °C (140 °F) or below 0 °C (32 °F). You must use protective clothing, such as gloves, when handling equipment at these temperatures. Display a warning notice concerning low or high temperature operation whenever temperature control equipment is in use. You should note that the hazard from extreme temperature can extend beyond the immediate area of the test.

Warnings



Crush Hazard - Take care when installing or removing a specimen, assembly, structure, or load string component.

Installation or removal of a specimen, assembly, structure, or load string component involves working inside the hazard area between the grips or fixtures. When working in this area, ensure that other personnel cannot operate any of the system controls. Keep clear of the jaws of a grip or fixture at all times. Keep clear of the hazard area between the grips or fixtures during actuator or crosshead movement. Ensure that all actuator or crosshead movements necessary for installation or removal are slow and, where possible, at a low force setting.



Hazard - Do not place a testing system off-line from computer control without first ensuring that no actuator or crosshead movement will occur upon transfer to manual control.

The actuator or crosshead will immediately respond to manual control settings when the system is placed off-line from computer control. Before transferring to manual control, make sure that the control settings are such that unexpected actuator or crosshead movement cannot occur.



Robotic Motion Hazard - Keep clear of the operating envelope of a robotic device unless the device is de-activated.

The robot in an automated testing system presents a hazard because its movements are hard to predict. The robot can go instantly from a waiting state to high speed operation in several axes of motion. During system operation, keep away from the operating envelope of the robot. De-activate the robot before entering the envelope for any purpose, such as reloading the specimen magazine.



Hazard - Set the appropriate limits before performing loop tuning or running waveforms or tests.

Operational limits are included within your testing system to suspend motion or shut off the system when upper and/or lower bounds of actuator or crosshead travel, or force or strain, are reached during testing. Correct setting of operational limits by the operator, prior to testing, will reduce the risk of damage to test article and system and associated hazard to the operator.



Electrical Hazard - Disconnect the electrical power supply before removing the covers to electrical equipment.

Disconnect equipment from the electrical power supply before removing any electrical safety covers or replacing fuses. Do not reconnect the power source while the covers are removed. Refit covers as soon as possible.

Warnings



Rotating Machinery Hazard - Disconnect power supplies before removing the covers to rotating machinery.

Disconnect equipment from all power supplies before removing any cover which gives access to rotating machinery. Do not reconnect any power supply while the covers are removed unless you are specifically instructed to do so in the manual. If the equipment needs to be operated to perform maintenance tasks with the covers removed, ensure that all loose clothing, long hair, etc. is tied back. Refit covers as soon as possible.



Hazard - Shut down the hydraulic power supply and discharge hydraulic pressure before disconnection of any hydraulic fluid coupling.

Do not disconnect any hydraulic coupling without first shutting down the hydraulic power supply and discharging stored pressure to zero. Tie down or otherwise secure all pressurized hoses to prevent movement during system operation and to prevent the hose from whipping about in the event of a rupture.



Hazard - Shut off the supply of compressed gas and discharge residual gas pressure before you disconnect any compressed gas coupling.

Do not release gas connections without first disconnecting the gas supply and discharging any residual pressure to zero.



Explosion Hazard - Wear eye protection and use protective shields or screens whenever any possibility exists of a hazard from the failure of a specimen, assembly or structure under test.



Wear eye protection and use protective shields or screens whenever a risk of injury to operators and observers exists from the failure of a test specimen, assembly or structure, particularly where explosive disintegration may occur. Due to the wide range of specimen materials, assemblies or structures that may be tested, any hazard resulting from the failure of a test specimen, assembly or structure is entirely the responsibility of the owner and the user of the equipment.



Hazard - Ensure components of the load string are correctly pre-loaded to minimize the risk of fatigue failure.

Dynamic systems, especially where load reversals through zero are occurring, are at risk of fatigue cracks developing if components of the load string are not correctly pre-loaded to one another. Apply the specified torque to all load string fasteners and the correct setting to wedge washers or spiral washers. Visually inspect highly stressed components such as grips and threaded adapters prior to every fatigue test for signs of wear or fatigue damage.

Table of Contents

Chapter 1	Introduction	9
	About these instructions	9
	System overview	10
	Purpose	10
	System components	10
	Frame configuration options	12
	Testing accessories	12
	System identification	12
	Product support	13
	Product documentation	13
	Calibration and verification	14
	Service Agreements/Contracts	14
	Calibration Upon Installation	14
	Calibration Services	14
Chapter 2	Installation Notes	15
	Existing transducer rationalization	15
	Computer system - ethernet card availability	15
	Interconnections	16
	Electrical interconnections	17
	Software and computer setup	18
	Load software	18
	Communication setup	18
	Initial startup	23
	Recommended procedure	23
	Install grip assembly components	24
	Optional accessories	24
Chapter 3	Additional System Details	25
	Frame	25
	Test space	25
	Tension crosshead	25
	Adjustable crosshead	26
	Grip assemblies	27
	Limit switch assembly	34
	Load measurement	34
	Position measurement	35
	Optional accessories	36

Controls and electronics	37
59 Series control unit	37
Computer system and controlling software	37
Electrical panel	38
Hydraulic system	39
Introduction	39
Hydraulic power supply	39
Manifold assemblies	41
Pressure settings	43
Oil cooling	43
Troubleshooting	44
Chapter 4 Parts Replacement	51
Introduction	51
Replacement of fuses	52
Inspect/replace power supply fuse	52
Replacement or repair of load cells	53

Chapter 1

Introduction

• About these instructions	9
• System overview	10
• Product support.	13
• Product documentation	13
• Calibration and verification	14

About these instructions

These instructions provide additional information beyond what is necessary to operate the various models of the DX testing systems. These instructions are intended for a laboratory or facilities supervisor, or Instron service personnel.

These instructions assume the following:

- You are an operator familiar with the operation of materials testing systems in general.
- Your system has been installed in its final location according to the requirements outlined in the system's Pre-Installation Manual.
- Your system consists of a frame, a hydraulic power supply, a control unit, a computer system with an Instron materials testing software package, and any testing accessories necessary to secure the specimen in the test space.
- Software test methods that are appropriate for your testing requirements are available.

These instructions do not include the development of test methods within the materials testing software. This is covered in more advanced training that can be provided by Instron Service and Training departments.

Throughout your documentation are NOTE, CAUTION and WARNING statements that alert you to important information. They appear as follows:



Notes provide further clarification on particular issues.

Caution

Cautions alert the user to situations that may cause equipment damage.

Warning



Warnings alert the user to situations that may cause serious personal injury or death.

System overview

Purpose

Warning



If the equipment is used in a manner not specified by Instron, the protection provided by the equipment may be impaired. Injury to personnel or damage to the system may result. Be sure to read and understand the material presented in these instructions and in any other accompanying instructions.

The Instron Model DX Static Hydraulic Universal Testing Systems are available in a variety of capacities. They have been developed for high-capacity testing to provide the forces necessary for static tension, compression, bend and shear testing. They are suited for tests on specimen samples such as bar, rebar, plate, tube, pipe, sheet, wire, and concrete. These frames feature two test spaces so that users can quickly change between tension and compression testing without having to remove heavy fixtures. This flexible design helps to ensure safety, reduce operator fatigue and improve productivity.

System components

Model DX systems consist of:

- Frame
- Hydraulic Power Supply (HPS)
- 59 Series control unit and other system controls and electronics
- Instron approved computer system with Instron materials testing software

[Figure 1](#) identifies the system components and various frame configurations (see “[Frame configuration options](#)” on page [12](#)).

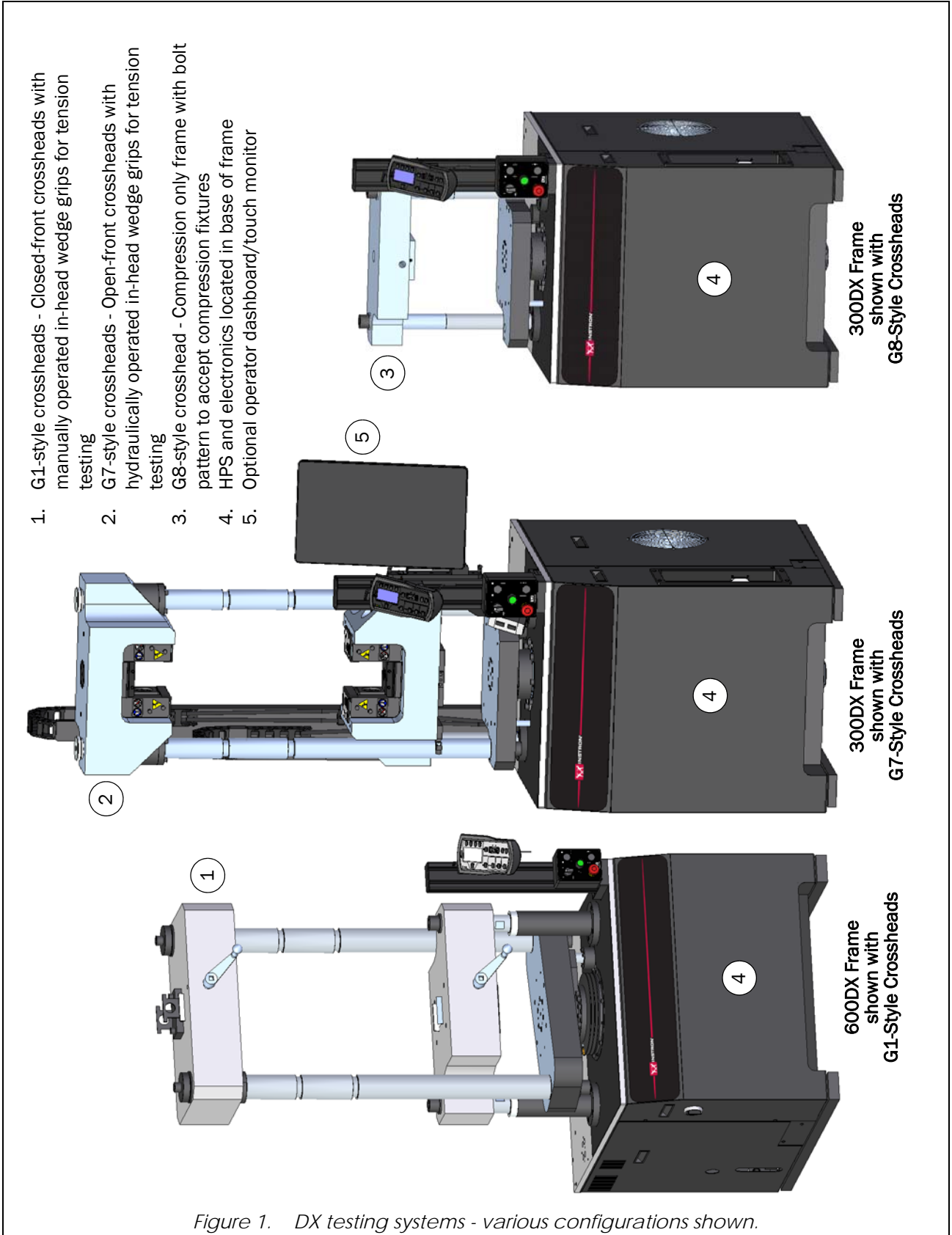

Figure 1. DX testing systems - various configurations shown.

Frame configuration options

Frames can be configured with a variety of options. These options include:

- Crosshead variations:
 - G1-style crossheads - Closed-front crossheads with manually operated grip assemblies for tension testing
 - G7-style crossheads - Open-front crossheads with hydraulically operated grip assemblies for tension testing
 - G8-style crosshead - Compression only frame with bolt pattern to accept compression fixtures
- Test opening variations:
 - E1 - Standard tension opening
 - E2 - Increase tension test space by: 610 mm (24 in) for 300DX frames, 406.4 mm (16 in) for 600DX frames

The configuration options selected for your frame are identified in the complete model number of the frame. The complete model number is defined as:

{Capacity (in kN)}{Model family}-{Controller}{Crosshead style option}{Test opening option}

Some examples would be:

300DX-V1-G1-E1, 300DX-V1-G7-E1, 600DX-V1-G1-E1, 600DX-V1-G8

It is very important to be aware of and understand the configuration of your frame as you perform various operations and procedures so that they can be performed correctly - the complete model number (in whole or in part) is used throughout this manual to identify specifications and procedures appropriate for your frame configuration. Knowing the complete model number of your frame is critical. To determine the complete model number (and thus configuration) of your frame, refer to one of the following:

- The frame serial tag (see [“System identification”](#) on page 12)
- The Instron quote

Testing accessories

Testing accessories are purchased separately from the frame. Testing accessories either provide a means to secure the specimen in the test space or provide additional functionality to the frame. Instructions on the installation, use and maintenance of Instron testing accessories are provided separately with each testing accessory. A variety of testing accessories are available. Contact your Instron Sales Representative for more information.

System identification

Your system has been given a unique serial number for system identification. This serial number can be found on the serial tag located on the rear of the frame (i.e. the frame serial tag).

The frame serial tag includes other important system information, including information on your frame's configuration. Frame configuration information can also be found on your Instron quote. Refer to [“Frame configuration options”](#) on page 12 for explanation of frame configuration.

Product support

Instron provides documentation, including manuals and online help, that can answer many of the questions you may have. It is recommended that you review the documentation sent with the system you purchased for possible solutions to your questions.

If you cannot find answers in these sources, contact Instron's Services department directly. A list of Instron offices is available on our website at www.instron.com. You may email your questions to service_support@instron.com (if your system is still in warranty, please include "IPG Warranty" in the subject line). In the US and Canada, you can call directly at 1-800-473-7838.

Product documentation

Instron offers a comprehensive range of documentation to help you get the most out of your Instron products. Depending on what you have purchased, your documentation may include some or all of the following:

Pre-Installation Manual	Information about preparing your site for installation of the system, receiving the system, and lifting and handling of the system.
Operating Instructions	How to use your system components and controls, and other frequently performed operating tasks.
System Concepts	Additional information about your system.
Online Help	Software products come complete with context sensitive help, which provides detailed information on how to use all software features.
Accessory Equipment Reference	How to set up and use any accessories you have purchased, for example grips, fixtures, extensometers, transducers, hydraulic power units, non-standard actuators, and environmental chambers.

We welcome your feedback on any aspect of the product documentation. Please email info_dev@instron.com with your comments.

Calibration and verification

Before shipment from the factory, your system is calibrated and tested to ensure that it meets its performance specifications. The factory calibration is traceable to national standards, but is not a full calibration meeting all the requirements of the relevant ISO and ASTM standards. ISO 7500-1 and ASTM E4 both state that a calibration must be performed after installation for it to meet their standard. This helps ensure that any changes in calibration during shipment are corrected before any test data is taken. These standards also recommend that verifications are performed annually or whenever the system is moved.

Service Agreements/Contracts

In many countries and territories Instron Service offers a variety of service agreements and contracts to cover such things as annual verification, maintenance, repair coverage, and hotline support for your system. Contact your local Instron office for details on a service agreement or contract that best matches your needs. A listing of Instron offices can be found on the Instron web site at www.instron.com.

Calibration Upon Installation

ASTM, ISO, and EN standards require the system be calibrated when it is installed or when it is moved or relocated. Instron calibrates the system at the factory, and provides a record of readings for the load cell. This frame may be verified on-site to ASTM E-4, BS 1610, DIN 51221, ISO 7500/1, EN 10002-2, JIS B7721, JIS B773 or AFNOR A03-501 standards. The factory calibration is not a complete verification to any current version of any of the above standards. Installation and Basic Software training are included with the purchase of your system. Verification services are available at a reduced rate if performed as part of the installation, but must be purchased separately. Contact your local Instron office for more information about our on-site verification services. Refer to “[Calibration Services](#)” below for more information about Instron’s calibration services.

Calibration Services

In addition to the initial calibration service available at installation, Instron recommends verifying your transducers on a regular schedule (at least annually) to ensure that your system operates properly and meets ISO and ASTM standards.

Instron’s Professional Services Department provides a wide range of calibration services including:

- Force
- Strain
- Torsion
- Temperature
- Crosshead displacement
- Crosshead speed

Contact your local Instron office for more information about our on-site verification services. Refer to “[Product support](#)” on page 13 for Instron’s contact information.

Chapter 2

Installation Notes

• Existing transducer rationalization	15
• Computer system - ethernet card availability	15
• Interconnections	16
• Software and computer setup	18
• Initial startup	23
• Install grip assembly components	24
• Optional accessories	24

Existing transducer rationalization

If you will be using existing extensometers or low-range load cells with your new system, the additional transducers may need to be rationalized in order to work correctly with the new system. Contact your local Instron office for more information about our on-site rationalization services. Refer to “[Product support](#)” on page 13 for Instron’s contact information.

If factory rationalization was purchased, these transducers will be requested 2-3 weeks prior to shipment of the system in order to integrate them. Some instruments can be rationalized separately from the shipment of the system, if necessary, to maintain your testing commitments. Contact your local Instron office for more information.

Field rationalization of some transducers is also available, though it is a more expensive option. This is often preferable because it will allow using the instrument on your existing system until the new system is installed.

Computer system - ethernet card availability

The system uses an Ethernet Frame Interface (EFI) to provide communication between the 59 Series control unit and the computer system. The EFI is housed inside the 59 Series control unit. Use of this EFI requires an Ethernet card in the computer system:

- If a new computer system is purchased as part of the testing system and is supplied from the factory, then the computer includes two Ethernet ports - one for use with the EFI and one for normal network use. The computer system is ready for use and no preparation is required.
- If the computer system is customer supplied, then it must include at least one Ethernet port for use with the EFI and, if the computer will be connected to a network, then it must include a second Ethernet port. Be sure the Ethernet cards/ports are installed in the computer.



The second Ethernet port must be used exclusively for communications between the computer and the 59 Series control unit. If you want to connect the computer to a network, you will need to use the first (Motherboard) Ethernet port or install an additional Ethernet card. Contact your IT department or Instron service for assistance if required.

Interconnections

The following interconnection information is provided for reference. It is not intended to be a complete step-by-step installation procedure, but it does provide a general guideline of what and how system components should be interconnected. Depending on the components supplied with your system, all the interconnections listed may not be necessary for your system. This list may also be used as a reference if it becomes necessary to move the system or frame at a later date.

Electrical interconnections

Before making electrical interconnections, all system components (including the computer system) should be unpacked and in place at the installation site. Also, the computer system components can and should be interconnected as outlined by the computer manufacturer. Check the electrical nameplate of each computer component and connect to an appropriate power source.

Refer to [Table 1](#) as you step through the interconnection process.

Table 1. Electrical connections required.

Cable	Connect From	Connect To
Ethernet crossover cable, male RJ45	Auxiliary Ethernet connection on rear of computer	Ethernet connection on 59 Series control unit
Load transducer cable, male 25-pin	LOAD connection on 59 Series control unit	Load transducer on frame
Position cable, male 9-pin	Hardwired to frame interface board inside base of frame	Position encoder on frame ¹
For systems that include an optional enclosure Interlock cable	Connection on side of frame base above 59 Series control unit	Enclosure interlocks - typically routed along inside of enclosure to its exit point
Frame main power cable	Frame (hardwired to frame)	Customer power supply of appropriate rating
For systems that include the optional Versachannel or Multichannel Coaxial cable, male BNC	SYNC (BNC) connection on 59 Series control unit	BNC connection on the Versachannel or Multichannel box
For systems that include the optional Expansion Channel Module 68-Way mini-D cable	Expansion port on 59 Series control unit	X1 connection on rear of Expansion Channel Module box

- Encoder cable may have been disconnected from encoder for shipment. Cable remains hardwired to frame interface board. Connect cable end to encoder on bottom of hydraulic cylinder.

Software and computer setup

When a new computer system is purchased as part of the testing system and is supplied from the factory, or if a customer supplied computer was returned to the factory for integration with the system, then the computer system and controlling software were set up at the factory before shipment. If either of these is the case with your system, this portion of the installation procedures is not required, continue system installation with “[Initial startup](#)” on page [23](#).

If the computer system is supplied such that it will be integrated into the system at the customer’s facility, then it is necessary to load and set up the controlling software and to set up the computer system for communication.

Load software

Follow procedures provided with the Materials Testing Software CD.

Communication setup

Recommended procedure:

1. Turn the system disconnect switch to ON (|).
2. Turn on the computer and perform the following to set up the network:
 - a. In Windows, choose the network connections tool per your operating system:
 - i. In **Windows XP** it is found under **Start/Control Panel**. Select the network card associated with the EFI; right click on it and select **Properties**. The Properties window will open. Select “Internet Protocol (TCP/IP)” and click on *Properties* ([Figure 2](#)).
 - ii. In **Windows 7** it is found under **Start/Control Panel/Network and Internet/Network and Sharing Center**. Click the **Local Area Connection** link for the network card associated with the EFI. The Properties window will open. Select “Internet Protocol Version 4 (TCP/IPv4)” and click on *Properties* ([Figure 2](#)).
 - b. On the Internet Protocol (TCP/IP) Properties window (see [Figure 3](#)) you must manually assign an IP address to the NIC card installed in the PC. Select the “Use the following IP address” radio button. Set the IP address to **169.254.1.2**. The Subnet mask should populate with **255.255.255.0**; if it does not, manually type it into the Subnet mask field. The Default gateway field can remain blank.
 - c. Click **OK** to exit the window.
3. Check that the lights on the front of the 59 Series control unit are illuminated as follows:
 - T indicator of the **SERVICE** display is green
 - A indicator of the **SERVICE** display is blinking red



*If the **SERVICE** display flashes the letter “F” during startup, it indicates that an error has occurred. Refer to “[Troubleshooting](#)” on page [44](#) for more information.*

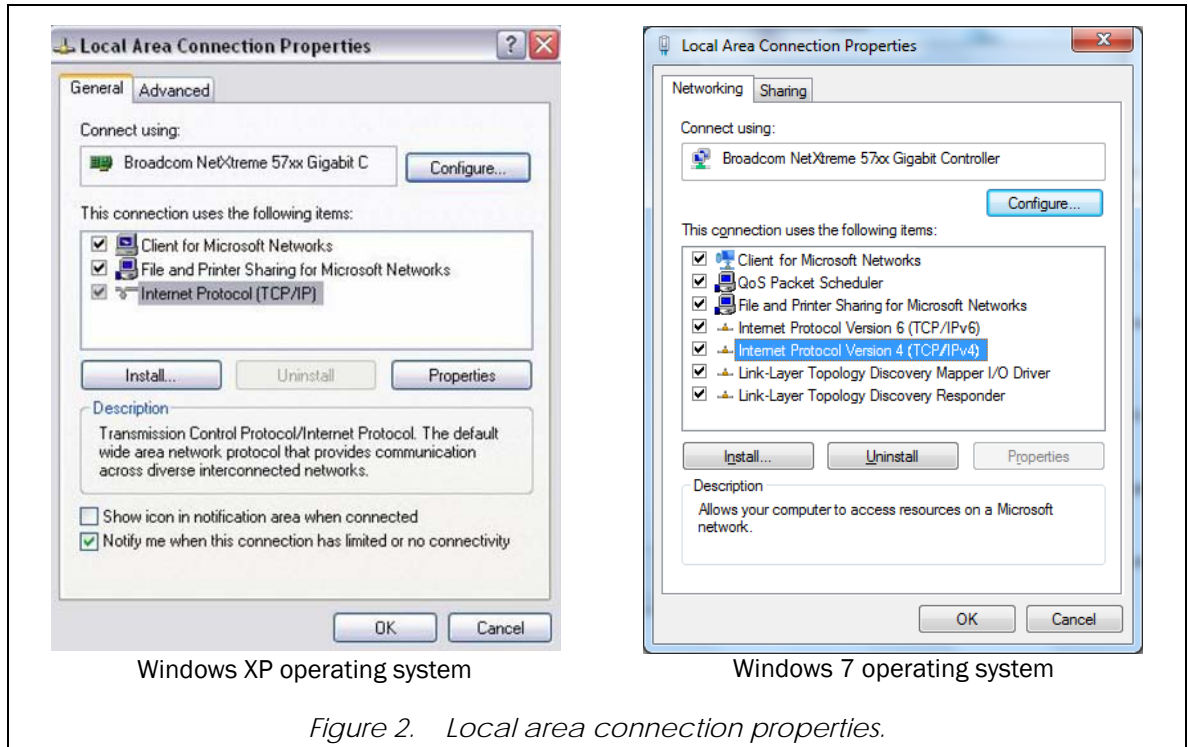

Figure 2. Local area connection properties.

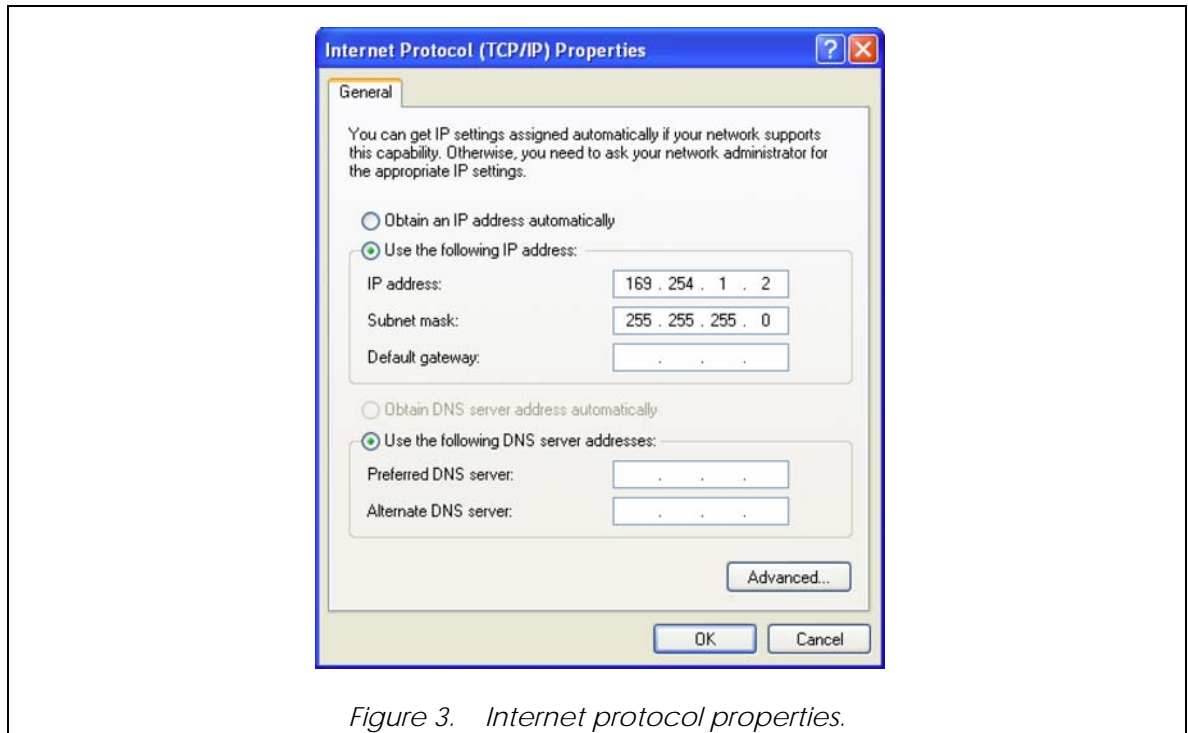

Figure 3. Internet protocol properties.

4. Check that the lights on the user control panel are illuminated as follows:
 - **POWER** is green
 - **FRAME STANDBY** is red
 - **TEST STOPPED** is red
5. Set up the controlling software to communicate via the Ethernet card that was previously installed. The procedure is dependent on which controlling software is used with the system, Partner or Bluehill. Perform the procedure for your software:
 - a. For systems with **Partner** software, perform the following:
 - i. Start Partner.
 - ii. From the Home screen, select **Tools** in the menu. (Ensure no procedures are open.)
 - iii. Select **Configure** from the drop-down menu.
 - iv. Select **Controller** to view the controller setup window.
 - v. On the General tab, verify the correct controller is selected ([Figure 4](#)).

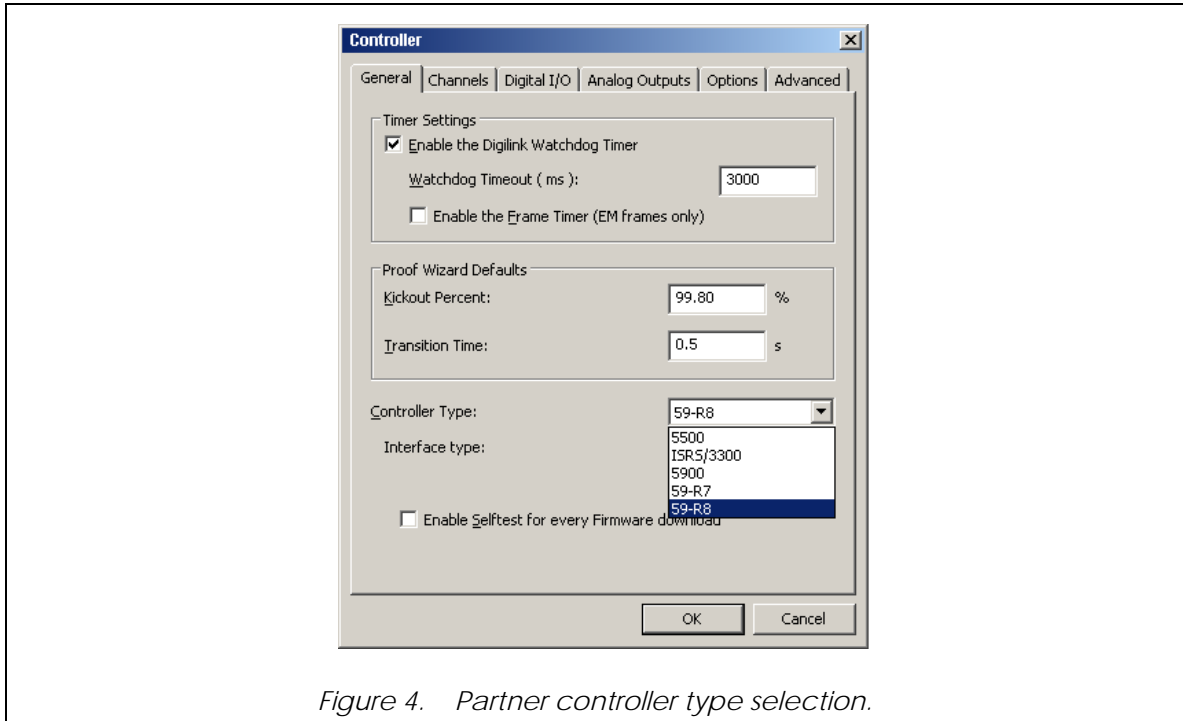

Figure 4. Partner controller type selection.

- vi. Select **Ethernet** as the Interface type ([Figure 5](#)); a third box appears for the MAC address.
- vii. In addition to an IP address, the EFI uses a unique MAC address. Click the Find button next to the MAC address field; the software will search for the device, get the MAC address and populate the field. Alternately, you can enter the MAC address manually. The MAC address can be found on the label affixed to the front of the 59-Series control unit (usually below the Ethernet connection). The MAC address is case sensitive. The first six digits (00-90-C2) indicate that the EFI is an Instron device. The last six digits are unique to that EFI to ensure that Partner only communicates with that specific EFI ([Figure 6](#)).
- viii. Click **OK** to exit the window.
- ix. Exit Partner and then restart Partner for the changes to take effect.

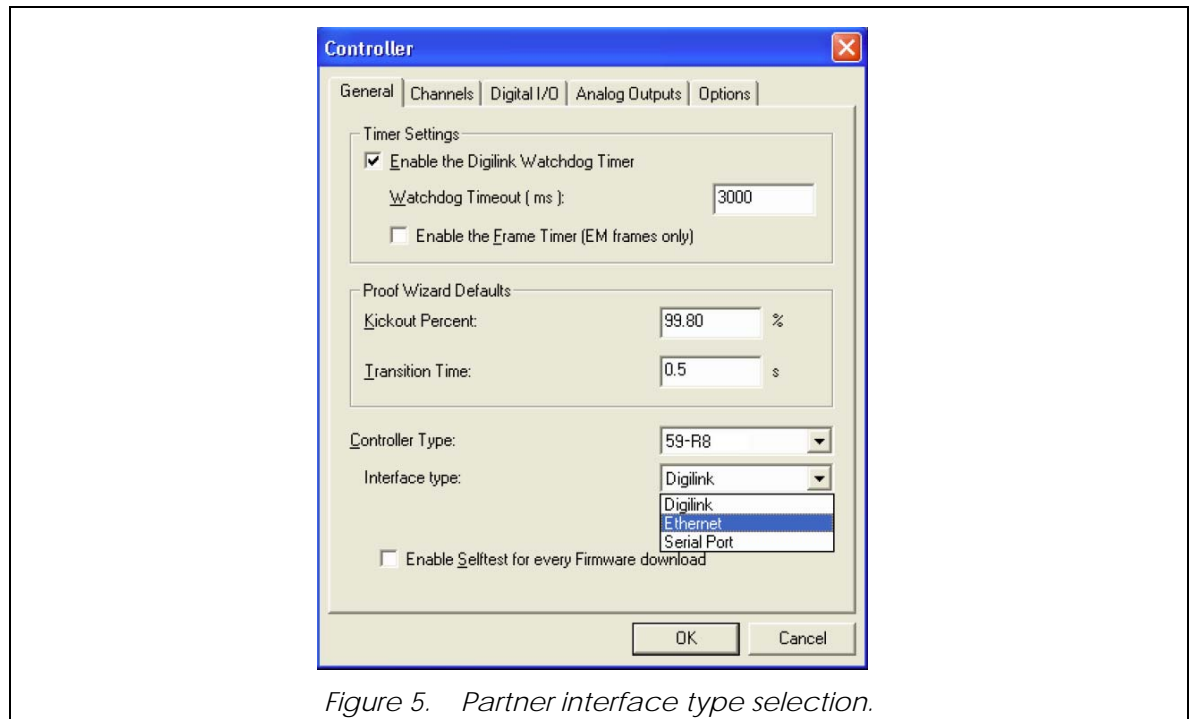

Figure 5. Partner interface type selection.

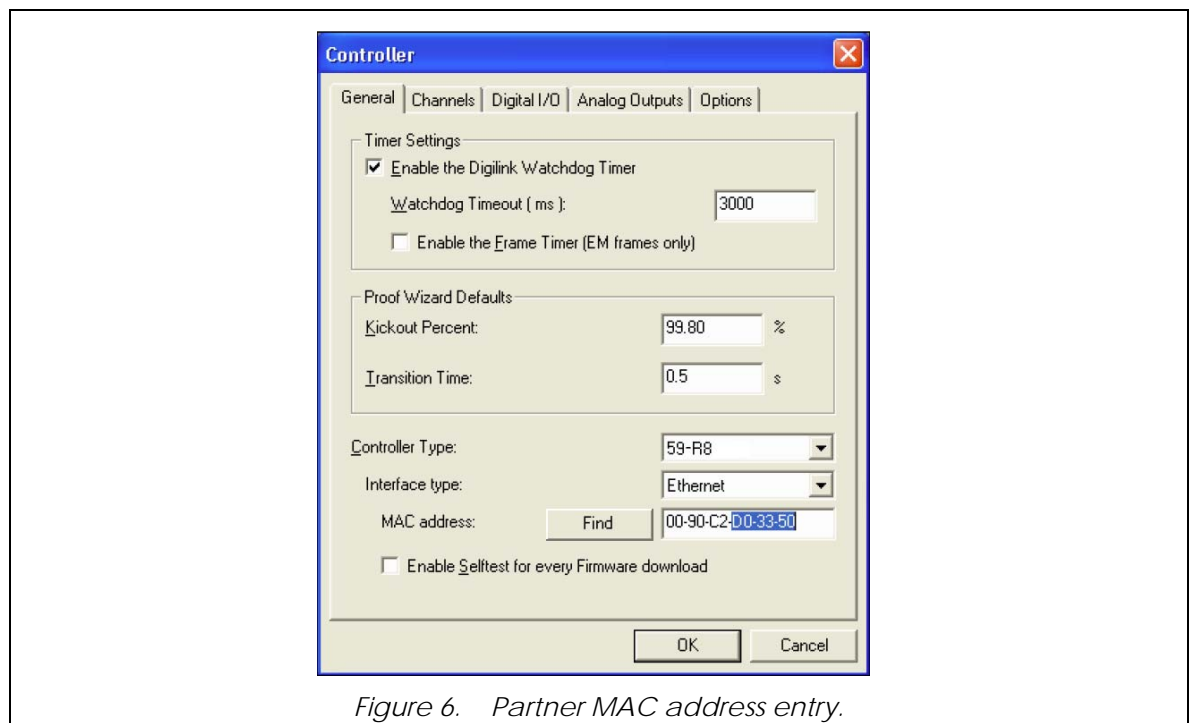

Figure 6. Partner MAC address entry.

- b. For systems with **Bluehill** software, perform the following:
 - i. Start Bluehill.
 - ii. Select the **Admin** button. (Ensure no methods are open.)
 - iii. On the Admin page, select **Configuration**.

- iv. Select **Frame** in the navigation bar (see [Figure 7](#)).
- v. Select the Controller type according to the **Controller Type** that is indicated on the front of the Bluehill CD case.

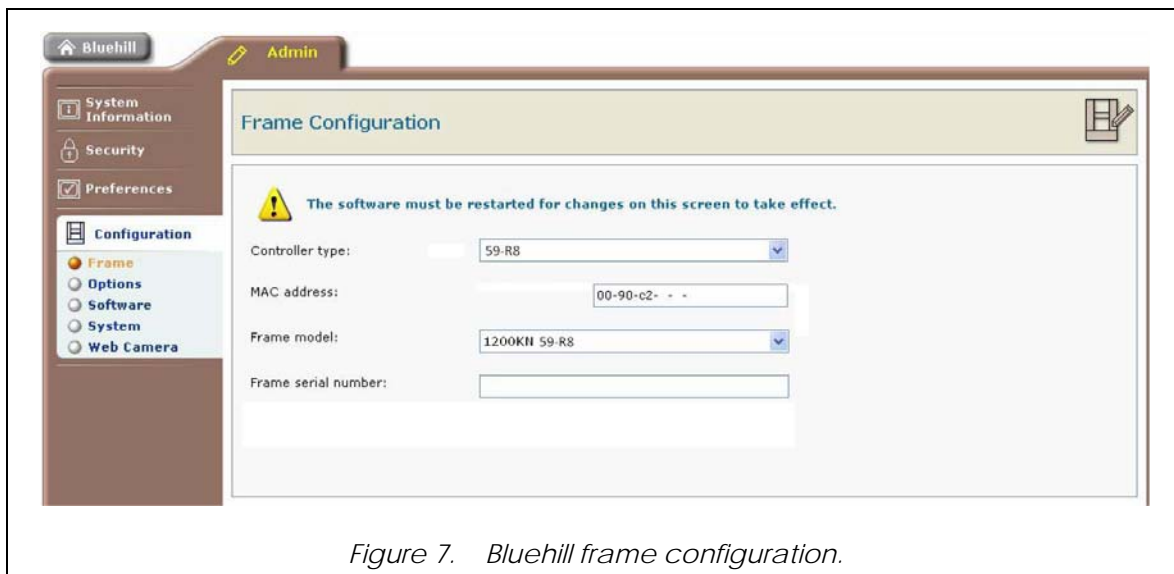

Figure 7. Bluehill frame configuration.

- vi. Enter the MAC address; the MAC address is case sensitive. In addition to an IP address the EFI uses a unique MAC address, which can be found on the label affixed to the front of the 59-Series control unit (usually below the ethernet connection). The first six digits (00-90-C2) indicate that the EFI is an Instron device. The last six digits are unique to that EFI to ensure that Bluehill only communicates with that specific EFI.
- vii. Select the Frame model according to the **Frame Selection** that is indicated on the front of the Bluehill CD case.
- viii. Enter the Frame serial number.
- ix. Close the Admin window.
- x. Exit Bluehill and then restart Bluehill for the changes to take effect.

Initial startup

Recommended procedure

1. Verify that the following have been completed:
 - The frame is secured to the foundation (if required)
 - The HPS reservoir is filled with the appropriate amount and type of oil
 - The air breather assembly is installed on the fill hole of the HPS reservoir
 - All system interconnect cables are installed and have secure connections
 - All Operating Instructions and accompanying documentation for the system have been read and understood by the operator
 - Any shipping hardware (typically painted red) has been removed from the frame
 - Any crosshead blocking has been removed from the frame, including any type of wooden blocks or metal plates that secure the crossheads together
2. Locate the Operating Instructions that were supplied with the system. You will be required to refer to procedures and information that are provided in the Operating Instructions as you perform the initial startup.
3. Ensure that the test space is clear - there should be no fixtures installed in the test space. This would **exclude** any fixtures that were installed at the factory and remained in the test space for shipment. These fixtures can remain in the test space. Also ensure that there is no shipping hardware on the frame.
4. Perform the “System Startup” procedure provided in Chapter 3 of the Operating Instructions that were supplied with the system.
5. Check that the frame is enabled. If the frame will not enable, see “[Troubleshooting](#)” on page 44, specifically [Problem No. 2](#) of the table. Once any problems are corrected, enable the frame.
6. Start the HPS by pressing the **Pump Start** button on the HPS controls; the **FRAME READY** indicator will illuminate. Immediately check the position of the piston within the hydraulic cylinder, the piston should be positioned so that it is neither fully retracted nor fully extended. Use the jog controls to move the piston if necessary - typically a separation of 6 mm (0.25 in) is sufficient. If the piston is in either of these conditions, the servo loop control could build up enough error to shutdown the HPS (the controlling software will display a “Position loop error”).
7. Using the **JOG** controls on the user control panel, stroke the hydraulic cylinder one full cycle to help bleed air out of the system and introduce hydraulic fluid into the system.
8. **For systems with G7-style crossheads**, use the grip controls to introduce fluid to the hydraulic grips. Open and close the grips several times.
9. It is necessary to bleed air from the hydraulic cylinder. This requires a procedure that must be performed by the Instron service engineer.
10. The system is now ready for normal operation. Before the system is operated any further, be sure to read and understand the material provided in the System Operating Instructions (supplied separately).
11. If the system will not be operated at this time, perform the “System Shutdown” procedure provided in the System Operating Instructions (supplied separately).

Install grip assembly components

For frames with G7-style crossheads, be sure that the grip dust covers (9, [Figure 11](#) on page 31) are installed on the crossheads. These are typically removed for shipment and must be installed before the frame is put into operation.

Optional accessories

Installation of accessories such as compression plates, tension rods, external grips, etc. that were purchased with your testing system are covered under separate instructions that are included with each accessory.

Some accessories are designed to be mounted temporarily in the frame, while others are designed to be mounted semi-permanently to the frame. Semi-permanent mounting means that the accessory is designed to remain mounted to, or near, the frame for most testing, regardless of whether or not the accessory is being used for a given test. The semi-permanent mounting is typically done for accessories that are large enough to make continuous installation and removal difficult and cumbersome.

Accessories that are considered semi-permanently mounted would be:

- Test space enclosures
- Furnace systems

Semi-permanently mounted accessories are typically not installed until the system is fully operational. Typically the Instron service engineer will assist with this during installation of the system. For more detailed information on these accessories, refer to the individual instructions that are included with each accessory.

Chapter 3

Additional System Details

• Frame.....	25
• Controls and electronics.....	37
• Hydraulic system.....	39
• Troubleshooting.....	44

Frame

Test space

The DX frame is a dual test space frame capable of static tension and compression testing (with exception - see NOTE below). The dual test space design provides both a dedicated tension test space (2, [Figure 9](#)) and a dedicated compression test space (6). To accomplish this, the frame is made up of two separate units: a loading unit and a fixed unit (see [Figure 8](#)). The loading unit applies the load to the specimen during the test. The loading unit components are: a tension crosshead, two notched columns, a compression table, and the hydraulic cylinder. The fixed unit acts as the rigid member during the test. The fixed unit components are: an adjustable crosshead, two screw columns, and the base. The fixed unit is supported in the base by a backlash eliminator assembly that provides enough force to support the static weight of the components and prevent backlash from appearing in the test load.



DX frames that are equipped with G8-style crossheads are single test space frames capable of static compression testing only.

Applying a load to the specimen is accomplished as follows. The HPS supplies hydraulic fluid, under pressure, to the hydraulic cylinder located inside the base of the frame. This pressure forces the piston out of the hydraulic cylinder which forces the loading unit upward so that a tensile load is applied to any specimen mounted between the tension and adjustable crossheads, and a compressive load is applied to any specimen mounted between the adjustable crosshead and the compression table.

The height of both the tension test opening and the compression test opening can be adjusted between tests to accommodate different load train heights and specimen lengths. This is accomplished by adjusting the position of the tension crosshead and/or adjustable crosshead. Adjusting the position of the tension crosshead will affect only the height of the tension test opening. For more information on adjusting the position of the tension crosshead, refer to information provided in the System Operating Instructions (supplied separately). Adjusting the position of the adjustable crosshead will affect the height of both the tension test opening and compression test opening. For more information on adjusting the position of the adjustable crosshead, refer to information provided in the System Operating Instructions (supplied separately).

Tension crosshead

The tension crosshead is supplied on frames with G1-style or G7-style crossheads only. The tension crosshead is equipped with grip assemblies for tension testing. For more information on the grip assemblies, refer to information provided in the System Operating Instructions (supplied separately). When it is desired to use other tension fixtures instead of the grip assemblies to grip a specimen, external

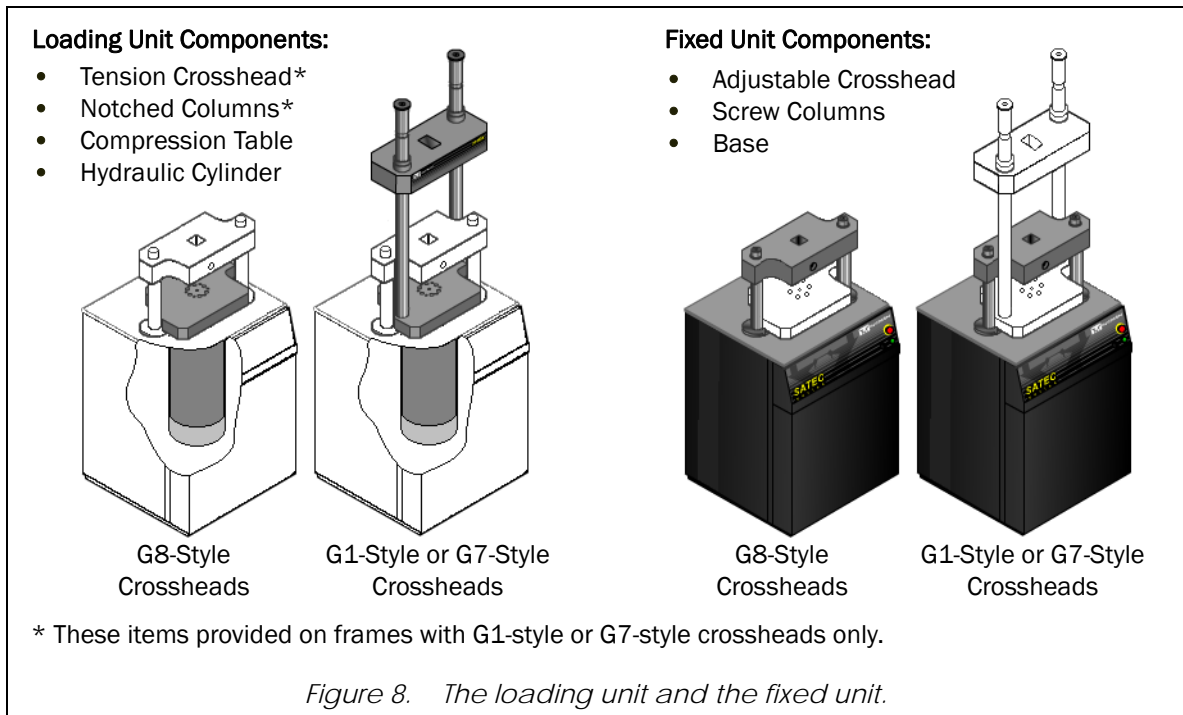

tension fixtures can be mounted to the tension crosshead with proper adapters. This is typically done by either clamping the adapter in the grip assemblies or by using the bolt pattern provided on the bottom of the crosshead to bolt the adapter (or fixture) to the crosshead. Some adapters may mount to the crosshead using the bolt pattern on the top of the crosshead. For more information on the bolt patterns, refer to information provided in the System Operating Instructions (supplied separately).

The tension crosshead (8a or 8b, [Figure 9](#)) is mounted to two notched columns (3) and is part of the loading unit. The position of the tension crosshead can be adjusted when it is necessary to change the height of the tension test opening. The crosshead can be placed at any of the available notches in the notched columns. Crosshead adjustment is only done between tests, never during a test. For procedures on adjusting the crosshead, refer to information provided in the System Operating Instructions (supplied separately).

Adjustable crosshead

For frames equipped with either G1-style or G7-style crossheads, the adjustable crosshead is equipped with grip assemblies for tension testing and a bumper plate on the bottom of the crosshead for attachment of compression accessories. For frames equipped with G8-style crossheads, the adjustable crosshead is only equipped with a bumper plate on the bottom of the crosshead for attachment of compression accessories. For more information on the grip assemblies, refer to information provided in the System Operating Instructions (supplied separately).

The adjustable crosshead is mounted to two screw columns and is part of the fixed unit. The position of the adjustable crosshead can be adjusted when it is necessary to change the height of either the tension test opening or compression test opening. A hydraulic motor is used to adjust the position of the adjustable crosshead. The operator controls the hydraulic motor through a control switch on the front of the frame base. Crosshead adjustment is only done between tests, never during a test. For more information on adjusting the position of the adjustable crosshead, refer to information provided in the System Operating Instructions (supplied separately).

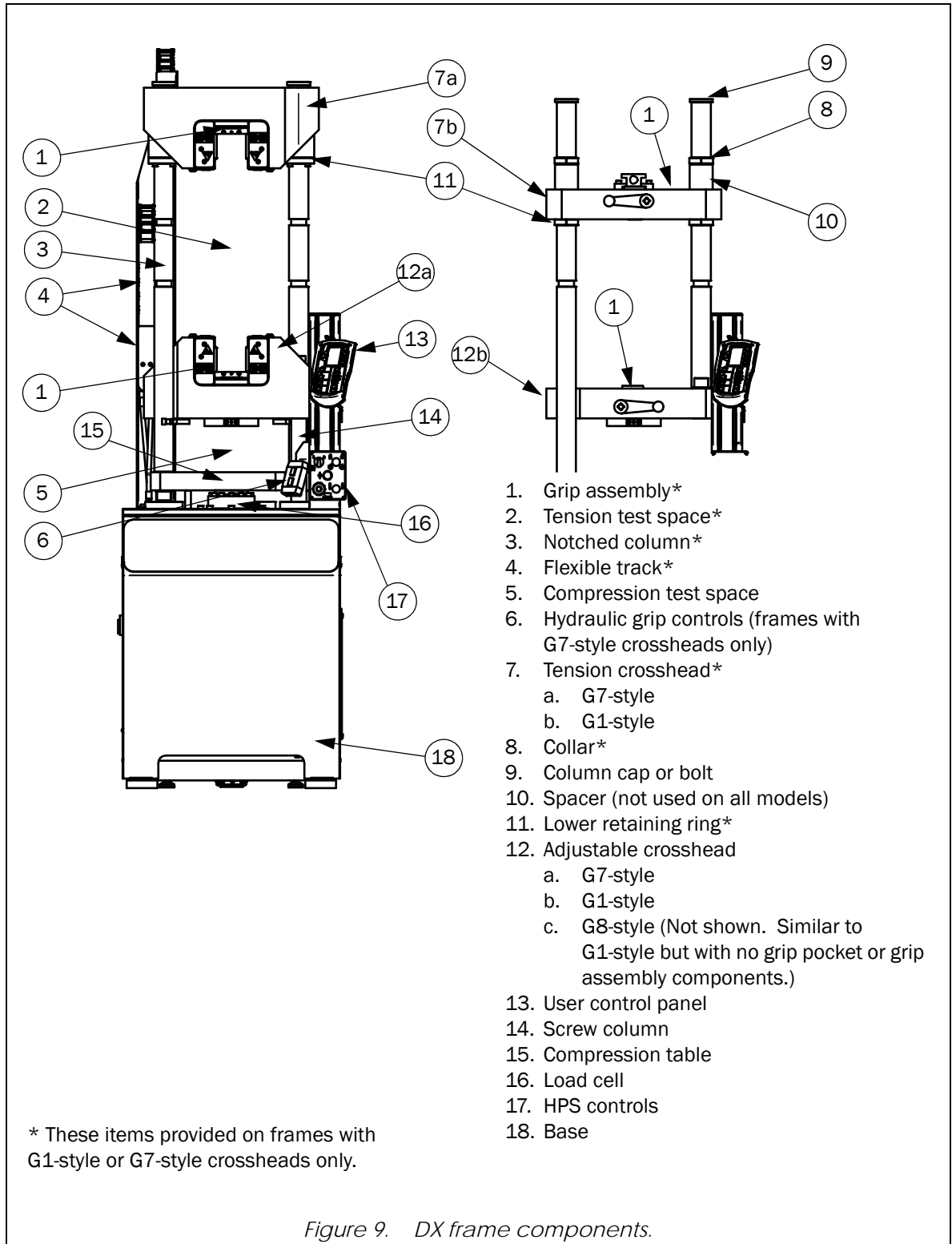

Grip assemblies

Grip assemblies are provided on frames with either G1-style or G7-style crossheads; they are not provided on frames with G8-style crossheads. Both the tension and adjustable crossheads are equipped with grip

assemblies that are designed to grip specimens for tensile testing. Frames can be purchased with either manual grip actuation (G1-style crossheads) or hydraulic grip actuation (G7-style crossheads).

Manual grip actuation - G1-style crossheads

For G1-style crossheads, the grip assemblies are actuated manually. Components of the grip assemblies are illustrated in [Figure 10](#). The operator uses a crank handle (2) to turn a pinion that is inside the crosshead. As the pinion turns, it engages the rack teeth on the grip jaws (10). This action lifts the grip jaws into the grip pocket (4). The wedge shape of the grip pocket forces the grip jaws to close and clamp the specimen. Filler plates (9) are placed between the grip jaws and the grip pocket. For guidance on use of filler plates, refer to information provided in the System Operating Instructions (supplied separately).

A grip stop plate (5), jaw retainers (7), and a bumper plate (11) are used to retain the jaws in the grip pockets. For the tension crosshead, the grip stop plate is mounted to the top of the crosshead to keep the grip jaws in the grip pocket during specimen recoil. The jaw retainers prevent the grip jaws from falling out of the bottom of the pocket. For the adjustable crosshead, the bumper plate keeps the grip jaws from falling out of the grip pocket.

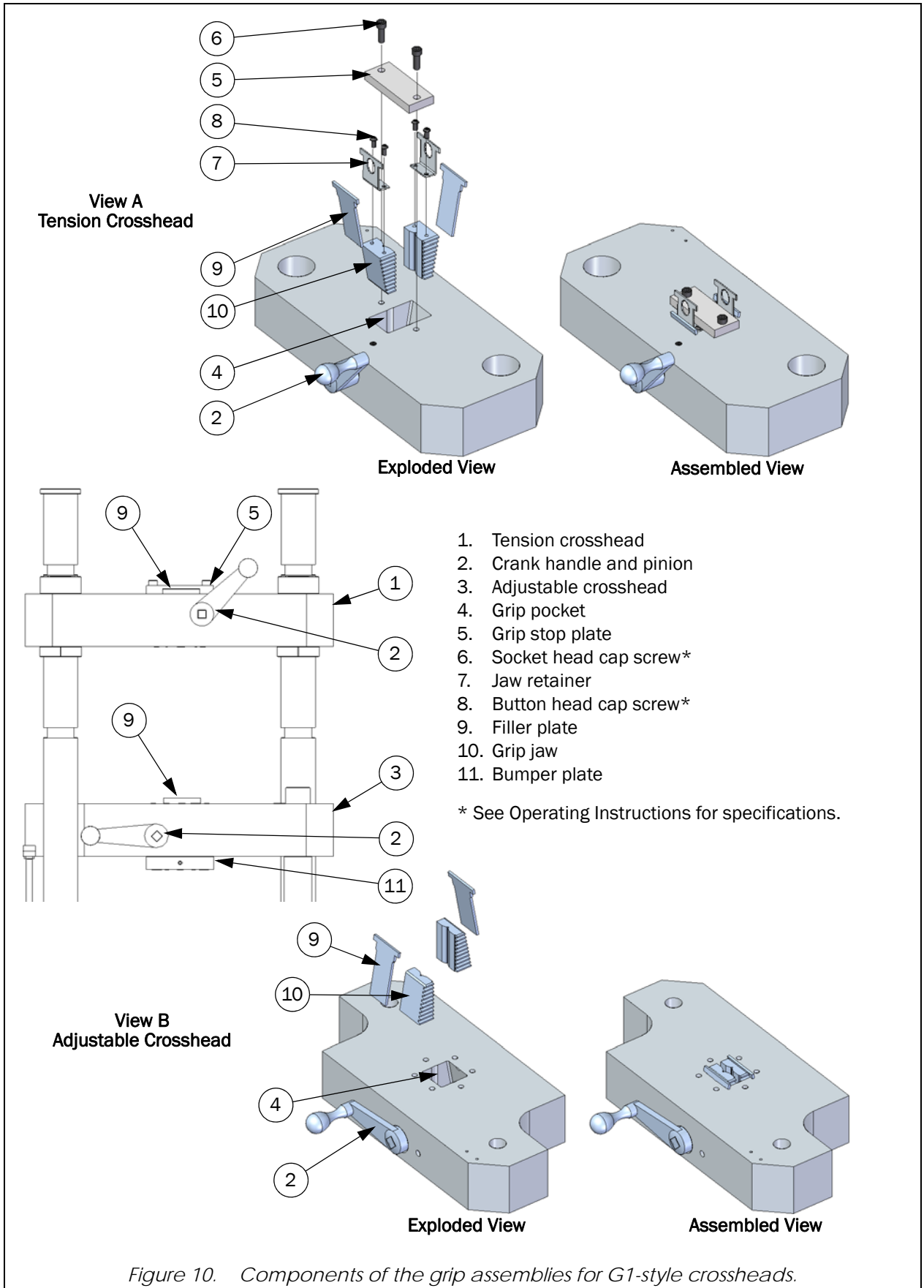
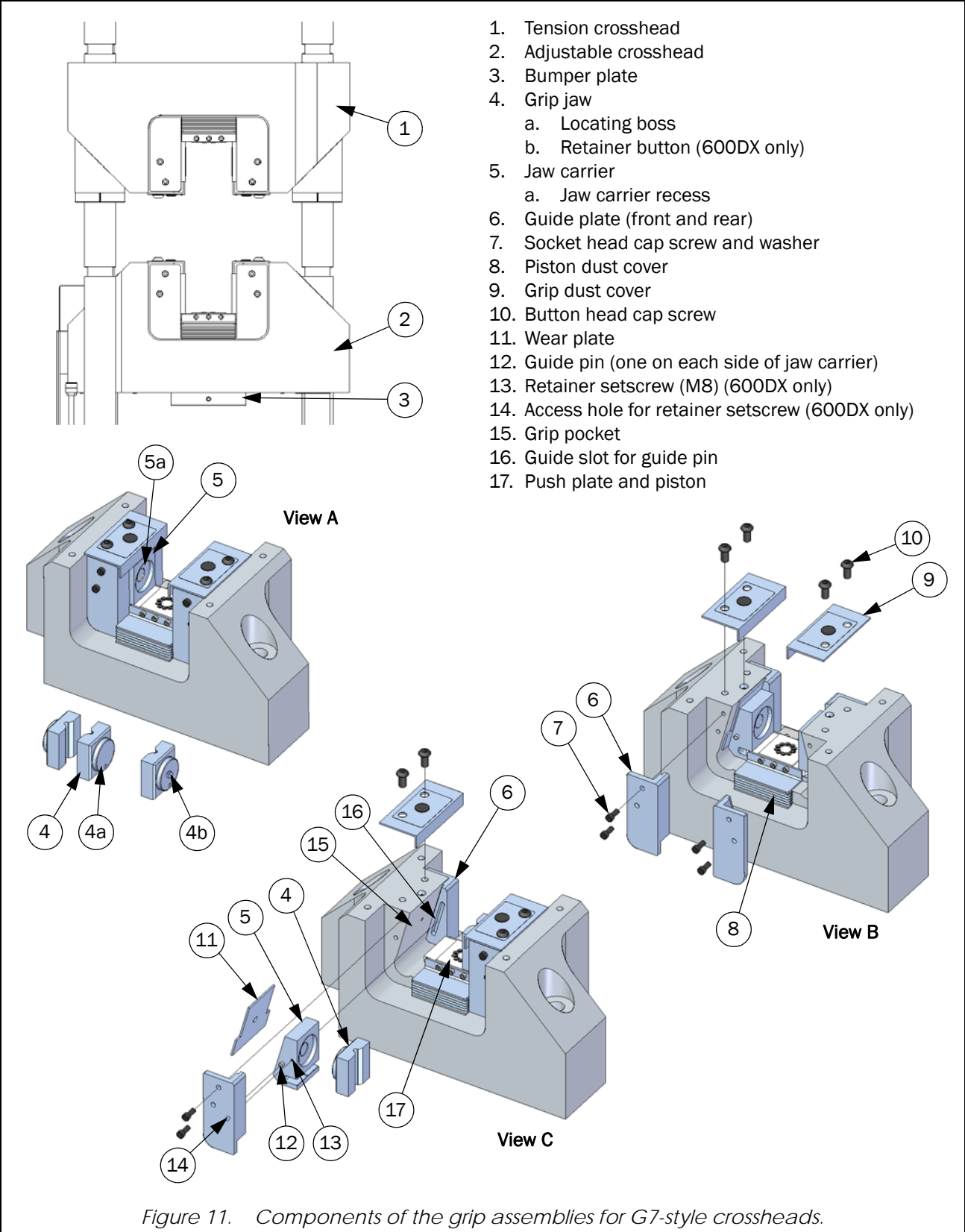

Figure 10. Components of the grip assemblies for G1-style crossheads.

Hydraulic grip actuation - G7-style crossheads

For G7-style crossheads, the grip assemblies are actuated hydraulically. Components of the grip assemblies are illustrated in [Figure 11](#). The operator uses a grip control handset ([Figure 12](#) on page [32](#)) to operate a hydraulic piston that is inside the crosshead. A push plate (17) is mounted to the piston. As the piston is extended, the push plate lifts the jaw carriers (5) in the grip pocket (15). The wedge shape of the grip pocket forces the jaw carriers and grip jaws to close and clamp the specimen. The grip jaws are held to the jaw carriers by either magnets or retainer setscrews, depending on the frame model. 300DX frames use magnets that are mounted in the jaw carrier recess (5a). The locating boss (4a) fits into the jaw carrier recess and is held by the magnet. 600DX frames use retainer setscrews (13) that are mounted in the jaw carrier. The locating boss (4a) fits into the jaw carrier recess (5a) and the retainer setscrew is tightened against the retainer button (4b). The retainer setscrews are tightened and loosened through an access hole (14) in each front guide plate (6). It is not necessary to remove the guide plate to adjust the retainer setscrew.

The oil required to operate the hydraulic piston is supplied by the HPS. The oil is directed to each crosshead by means of a hydraulic grips manifold mounted in the frame base. Once the oil reaches the crosshead, the oil is routed through a speed control manifold and to the hydraulic piston.



Grip controls

Warning

These grip assemblies are designed to grip specimens for testing. Therefore, an unavoidable pinching hazard exists. Make sure to read and understand all installation, removal and operating instructions before using the grip assemblies!

A hand-held grip control unit (Figure 12) is supplied to control operation of the hydraulic grips. The unit is magnetically mounted to a bracket on the front left corner of the base plate. The control unit can be removed from its bracket for in-hand use or can be used while mounted to the bracket.

The controls consist of two three-position rocker switches, one to operate the upper grips and one to operate the lower grips. Pressing one end of the rocker switch will actuate the jaws according to the labeling on the control unit (see Figure 12). Each switch operates as a momentary-type when it is in the **Open** position and as a latch-type when it is in the **Close** position. When a switch is placed in the **Open** position and then released, it automatically returns to its **Neutral** position and grip motion stops. When a switch is placed in the **Close** position, it latches in this position and closes the jaws fully. Be sure fingers or hands are not between the grip jaws when closing the jaws. The switch must remain in the **Close** position once the specimen is clamped and during testing. Do NOT place the switch in the **Neutral** position until the specimen has been removed from the grips.



*If a switch is in the **Close** position and main power is lost to the frame*, the grips will stop and hold their current position; also the switch will remain latched in the **Close** position but will be put into **Neutral** mode (i.e. will not function). When power is restored to the frame, the grips and the grip controls will remain in this hold/neutral condition until the switch is reset. The switch must be reset to restore grip function. To reset the switch, move it to the **Neutral** position and then operate as desired.*

** For conditions that result in loss of main power to the frame, refer to the System Operating Instructions (supplied separately).*

The clamping speed of the grip jaws was set at the factory; refer to “Clamping Speed” on page 33. It is not recommended that the factory settings be changed; keep in mind that faster clamping speeds increase the risk of operator injury.

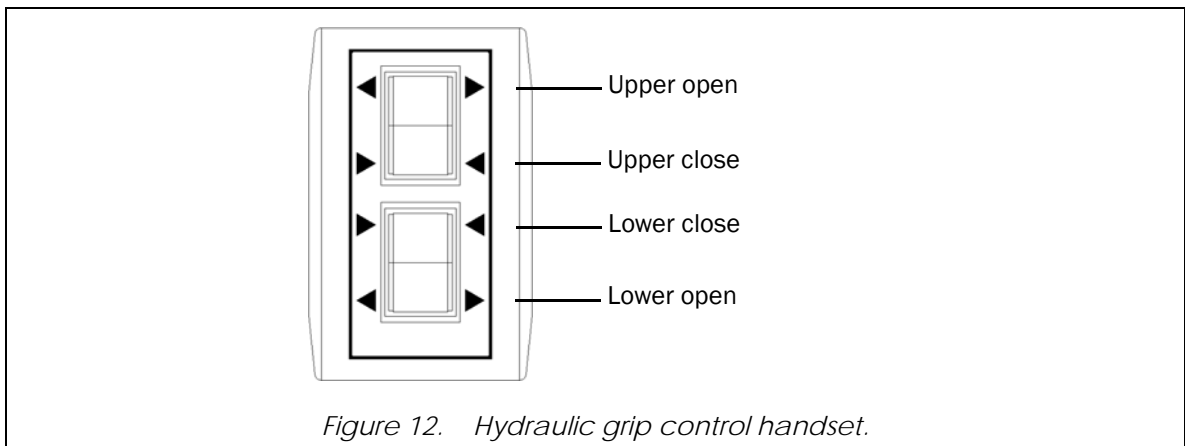

Figure 12. Hydraulic grip control handset.

Clamping Speed

Warning



Factory clamping speed is set to 4 mm/sec (0.16 in/sec) closure rate or less. A hazard to operators may be created if the clamping speed is adjusted faster than 4 mm/sec (0.16 in/sec).

Use caution if adjusting the clamping speed of the jaws. The jaws can be adjusted to move very quickly. Keep fingers and hands free of jaws.

The speed at which the grip jaws close or open can be adjusted by the flow control valves located on the speed control manifolds. A speed control manifold is located on the rear of each crosshead. A separate flow control valve is provided for the clamping speed and unclamping speed, see [Figure 13](#). To adjust a flow control valve:

1. Loosen locknut (see [Figure 13](#)).
2. Turn the adjustment knob as desired; increase speed by turning the knob counterclockwise and decrease speed by turning the knob clockwise.
3. Tighten the locknut.
4. Check jaw operation before inserting a specimen or performing a test.

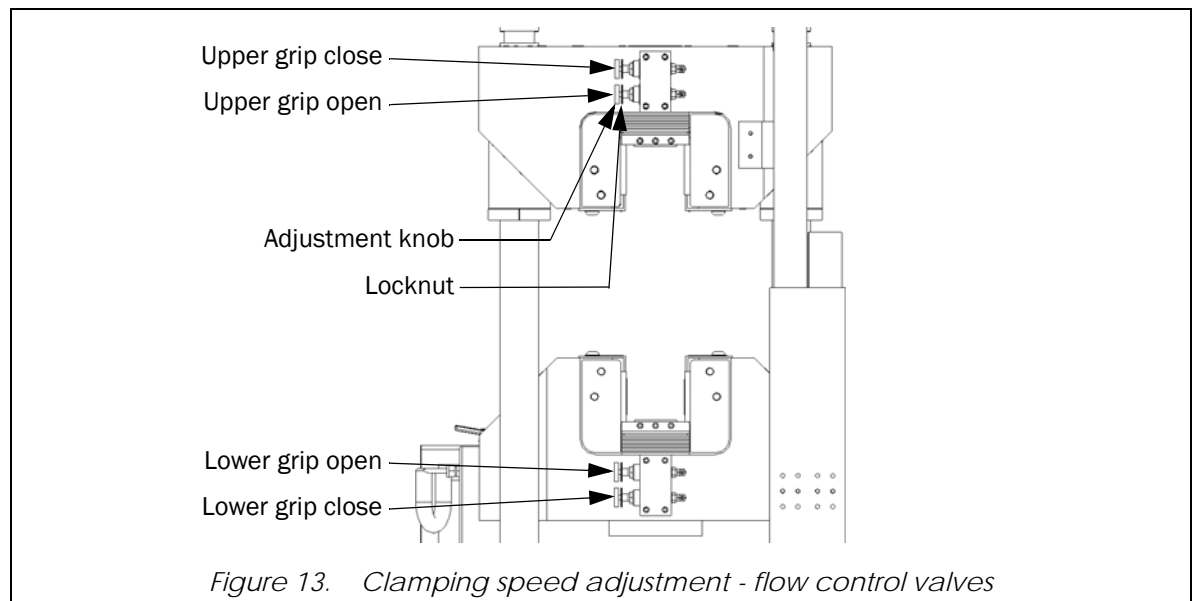

Limit switch assembly

A limit switch (2, [Figure 14](#)) is mounted to the underside of the base plate (1). The purpose of the limit switch is to protect the hydraulic cylinder from overtravel. The limit switch is actuated by a guide rod (3) that is mounted to the piston (8a). This allows the guide rod to move in conjunction with the piston. The guide rod extends through the base plate into the base (see [Figure 14](#)). As the piston reaches the limit of its travel, the stop collar (4) on the guide rod will trip the limit switch. When the limit switch is tripped, an electrical signal is sent to the 59 Series control unit and the controls shut down the HPS. The limit switch must be reset before the HPS can be restarted. To reset the limit switch, the frame must unload and allow the piston to travel away from the limit switch. The frame can only unload by gravity. To increase the unload rate, the dump valve can be manually opened by turning the system disconnect switch OFF. Once the frame is unloaded, turn the disconnect switch back ON and restart the system.

600DX frames have an additional limit switch. The purpose of this limit switch is to prevent the screw columns from running out of the backlash nuts while jogging the adjustable crosshead in either direction (up or down). When the limit switch is tripped, the crosshead motor stops and can not be operated in that direction until the limit switch is reset. The adjustable crosshead can only be operated in the opposite direction. Jog the adjustable crosshead away from the limit that was tripped to reset the limit switch and resume normal operation.

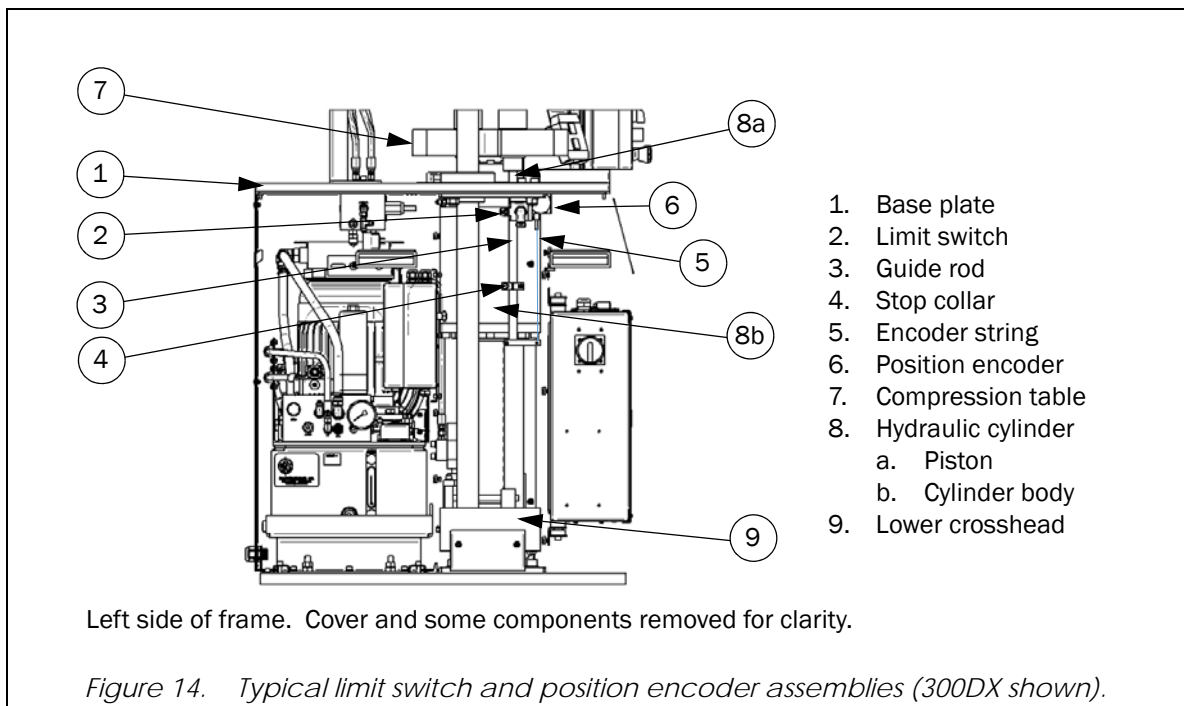

Load measurement

A strain gauged load cell is used to measure the force applied to the test specimen. The load cell (17, [Figure 9](#) on page 27) is mounted between the compression table and piston. This mounting arrangement provides a load measuring system that is independent of the hydraulic system. This means that the force measured by the load cell is free of interference due to piston friction and hysteresis; it is a direct force measurement.

Because of the dual test space design of the frame, the load cell are always subjected to a compressive load - even during a tensile test. The controlling software will report the load on the specimen in the appropriate direction (tension or compression) according to the test setup.

Caution

The controlling software is equipped with overload protection for the load transducer. The overload protection should prevent damage to the load transducer during a test by shutting off the HPS when an overload condition occurs.

Position measurement

A position encoder is used to determine the position of the piston inside the hydraulic cylinder. For specifications, refer to information provided in the System Operating Instructions (supplied separately). All encoders are digital quadrature style encoders.

DX-300 models use a string-type encoder (see [Figure 14](#)). The encoder is mounted to either the bottom of the base plate or lower crosshead depending on frame model. Piston movement is transferred to the encoder by a guide rod that is attached to either the bottom of the compression table or piston (depending on frame model) and extends through the base plate. The encoder string is attached to the bottom of the guide rod. As the piston and compression table move up and down, the guide rod also moves and actuates the encoder string which produces an electrical signal in the encoder. The electrical signal is transmitted to the 59 Series control unit. The 59 Series control unit converts the signal into the relative position of the loading unit in relation to a stationary frame member.

DX-600 models use a Micropulse Linear transducer. (see [Figure 15](#)). The encoder is mounted to the bottom of the cylinder. The Micropulse absolute quadrature output linear transducer is a magnetostrictive linear displacement transducer that provides electrical output signals in ABZ quadrature format. The electrical signal is transmitted to the 59 Series control unit. The 59 Series control unit converts the signal into the relative position of the loading unit in relation to a stationary frame member.

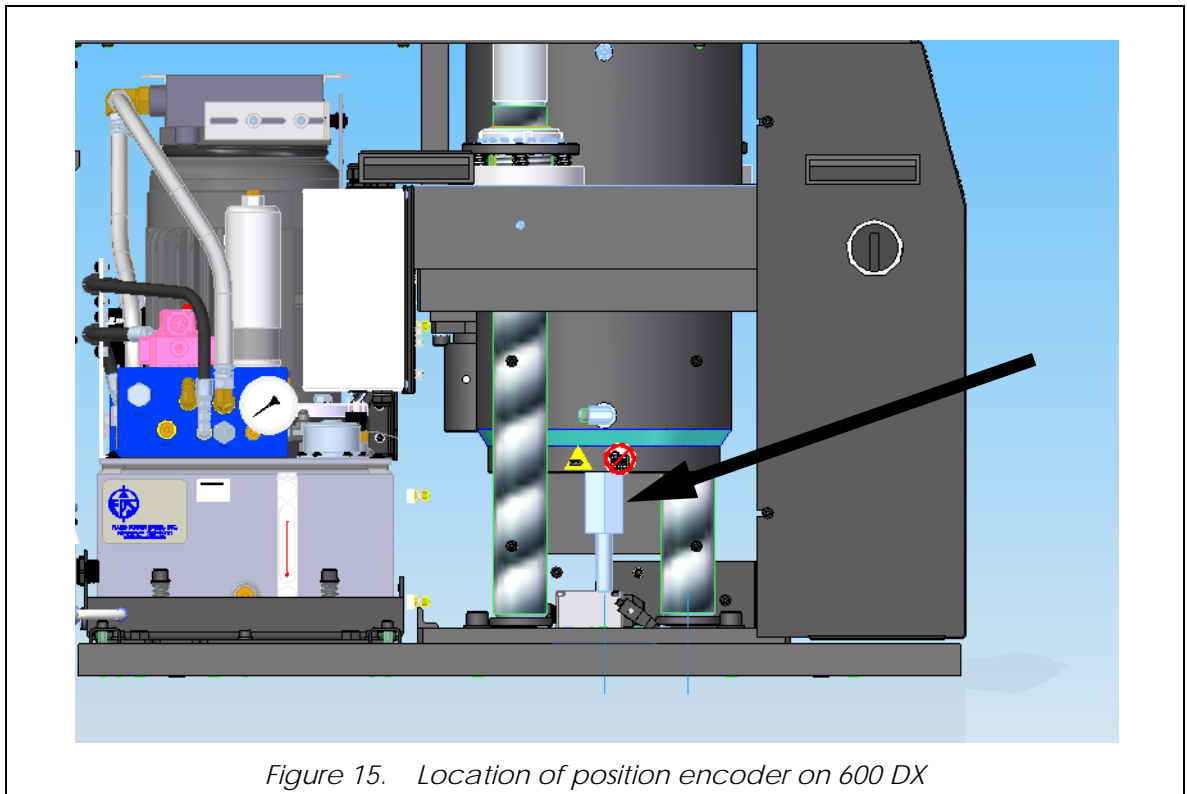

Optional accessories

Instron offers a wide variety of testing accessories that can be used with the DX frame. Some are designed to be mounted temporarily in the frame, while others are designed to be mounted semi-permanently to the frame. Semi-permanent mounting means that the accessory is designed to remain mounted to, or near, the frame for most testing, regardless of whether or not the accessory is being used for a given test. The semi-permanent mounting is typically done for accessories that are large enough to make continuous installation and removal difficult and cumbersome. This section will **briefly** discuss these semi-permanently mounted accessories. For more detailed information on these accessories, refer to the individual instructions that accompany each accessory.

For information on the wide variety of testing accessories that are offered by Instron, contact your local Instron Sales Representative as directed on page 13. Your Sales Representative can help you select accessories that best fit your testing needs.

- **Test space enclosure:** Test space enclosures surround the frame to retain specimen debris and prevent disturbance of the test in progress. Enclosures are typically floor mounted.
- **Furnace system:** A furnace system provides high temperature testing capability. The furnace system includes a mounting bracket for mounting to the frame; typically on the base. The mounting bracket permits rotation of the furnace so that it can be removed from the test space when not in use.
- **Tee-slot table:** Tee-slot tables provide additional methods for mounting accessories to the frame table. The tee-slot table mounts directly to the frame table. Before shipment from the factory, it is mounted to the frame and typically remains installed for shipment.

Controls and electronics

59 Series control unit

The 59 Series control unit (Figure 16) is located inside the frame base. The unit houses control components that: receive and process data from the various system transducers; communicates with the system's controlling software; and provides feedback to the system's servo valve to operate the frame as set up in the controlling software. The control components consist of a digital signal processor card, transducer signal conditioning cards, and an optional analog outputs card (when purchased).

External connections to the control components are made on the panel face at the side of the frame base. Connection descriptions are outlined in Table 2.

Table 2. 59 Series control unit function descriptions.

LOAD:	A female 25-pin interface that connects the system's load cell to the transducer conditioning card.
STRAIN 1: (optional)	A female 25-pin interface that connects an extensometer to an optional transducer conditioning card.
STRAIN 2: (optional)	A female 25-pin interface that connects an extensometer to an optional transducer conditioning card. (Typically only required for transverse strain or other dual extensometer setups.)
ETHERNET:	A connection for communication with the computer.
I/O: (optional)	Allows connection of analog chart recorders and plotters, etc. Features 4 zero suppressed and scaled 10V outputs via BNC connectors. A 25 pin D connector provides recorder pulse drive, 4 logic line outputs and 4 logic line inputs to trigger internal and external events.
SERVICE:	A connection for optional communications modem for remote diagnostics.
SERVICE Display:	Provides an indication of self-tests that are performed by the controls during system startup. You should see the following general sequence: the two 7-segment LEDs count up to "21" and then back down, and then the letter "P" will flash alternately with the number "22". This entire sequence typically takes between one and two minutes to complete. "P" indicates the all self-tests have passed. If the LEDs should flash the letter "F" at any time during the sequence, this indicates that a self-test has failed. If this occurs, you should contact your local Instron Services department as directed on page 13 for assistance in troubleshooting the failure. When conditions are normal, the T indicator is green and the A indicator is blinking red.

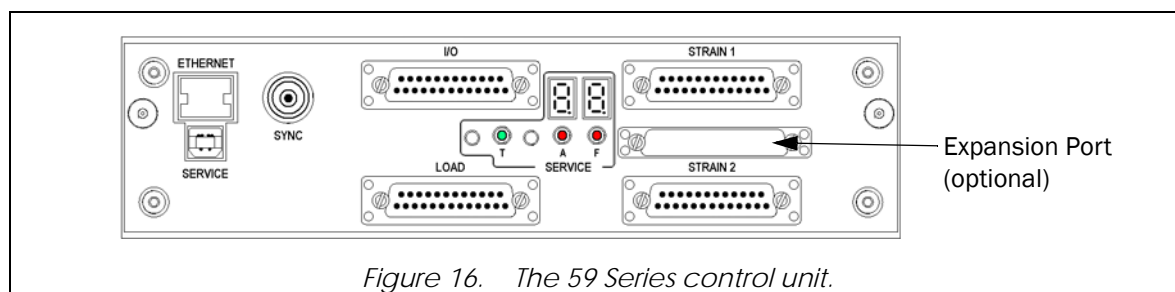

Figure 16. The 59 Series control unit.

Computer system and controlling software

The computer system is the operator communication link with the various system controls and the frame. Operators enter information and control parameters into the computer by way of the controlling software package.

The 59 Series control unit receives messages from the computer and sends the message to the testing system to perform the required operation. While testing, the controller receives data from the load and position transducers on the frame and sends the data to the computer. A frame interface board mounted inside the control unit provides signal interfacing between the controller and the system components.

Communication between the 59 Series control unit and the computer is accomplished through an Ethernet Frame Interface (EFI) that is mounted inside the 59 Series control unit.

For detailed information on the computer system, please refer to the computer manufacturer's literature that was provided with the system. For more information on the controlling software, refer to the software's On-line Help system or to the manual provided.



Computer systems are typically purchased from Instron with the testing system, however they may be customer supplied. If this is the case, refer to any information provided by the computer vendor in regards to its operation, warranty, etc. Instron is not responsible for customer supplied equipment.

Electrical panel

Warning



Disconnect the electrical power supply before removing the covers to electrical equipment.

Disconnect equipment from the electrical power supply before removing any electrical safety covers to replace fuses, inspect or clean the system. Do not reconnect the power source while the covers are removed. Refit covers as soon as possible.

System electronics are mounted on an electrical panel. The panel is mounted inside the front of the frame base. The electrical panel houses:

- A motor starter for the pump motor, with overloads
- A frame interface board
- A +/-12VDC power supply for the frame interface board
- A 59 Series control unit that houses the conditioning cards and digital signal processing card
- A +5/+12/-12VDC power supply to provide power to the 59 Series control unit

Hydraulic system

Introduction

Warning



Shut down the HPS and discharge hydraulic pressure before disconnecting any hydraulic fluid coupling.

Do not disconnect any hydraulic coupling without first shutting down the HPS and discharging stored pressure to zero. Tie down or otherwise secure all pressurized hoses to prevent movement during system operation and to prevent the hose from whipping about in the event of a rupture.

The hydraulic system includes any component that controls or routes hydraulic fluid (oil) through the testing system. For specifications of the hydraulic oil, refer to maintenance information provided in the System Operating Instructions (supplied separately).

Hydraulic power supply

The function of the HPS is to act as the power supply for the frame. This includes powering the hydraulic cylinder, crosshead motor, and hydraulic grip actuators (for frames with G7-style crossheads). The HPS is a variable pressure unit; it creates hydraulic pressure as required depending on system demand.

The HPS is enclosed in the rear of the frame base. The components of the HPS can vary depending on the configuration of the system. In general however, major components of the HPS are: a reservoir; a pump; an electric motor; a heat exchanger; one or more manifold assemblies; and the hydraulic fluid (oil). [Figure 17](#) identifies typical HPS components. An electrical panel mounted inside the base houses the motor starters, with overloads, for the electric motor.

When the HPS is on, the hydraulic cylinder should be positioned so that the piston is neither fully retracted nor fully extended. When the hydraulic cylinder is in either of these conditions, it is difficult for the 59 Series controls to maintain the position and the servo loop control could build up enough error to shut down the HPS.

Reservoir

Caution

DO NOT start the HPS without the screen trapper or air breather assembly installed on the reservoir. Starting the HPS with the solid cap (that is used for shipping) on the reservoir instead of the air breather assembly could cause pump cavitation.

The reservoir holds the oil that is needed to operate the various hydraulic components. For approximate reservoir capacity, and information on adding oil to or changing the oil in the reservoir, refer to maintenance information provided in the System Operating Instructions (supplied separately). The reservoir is equipped with a sight gauge, air breather assembly and screen trapper.

Sight gauge

The reservoir is equipped with an oil level and temperature sight gauge. The sight gauge (4, [Figure 17](#)) is visible through the opening provided on the right side of the frame base. The reservoir should be filled so

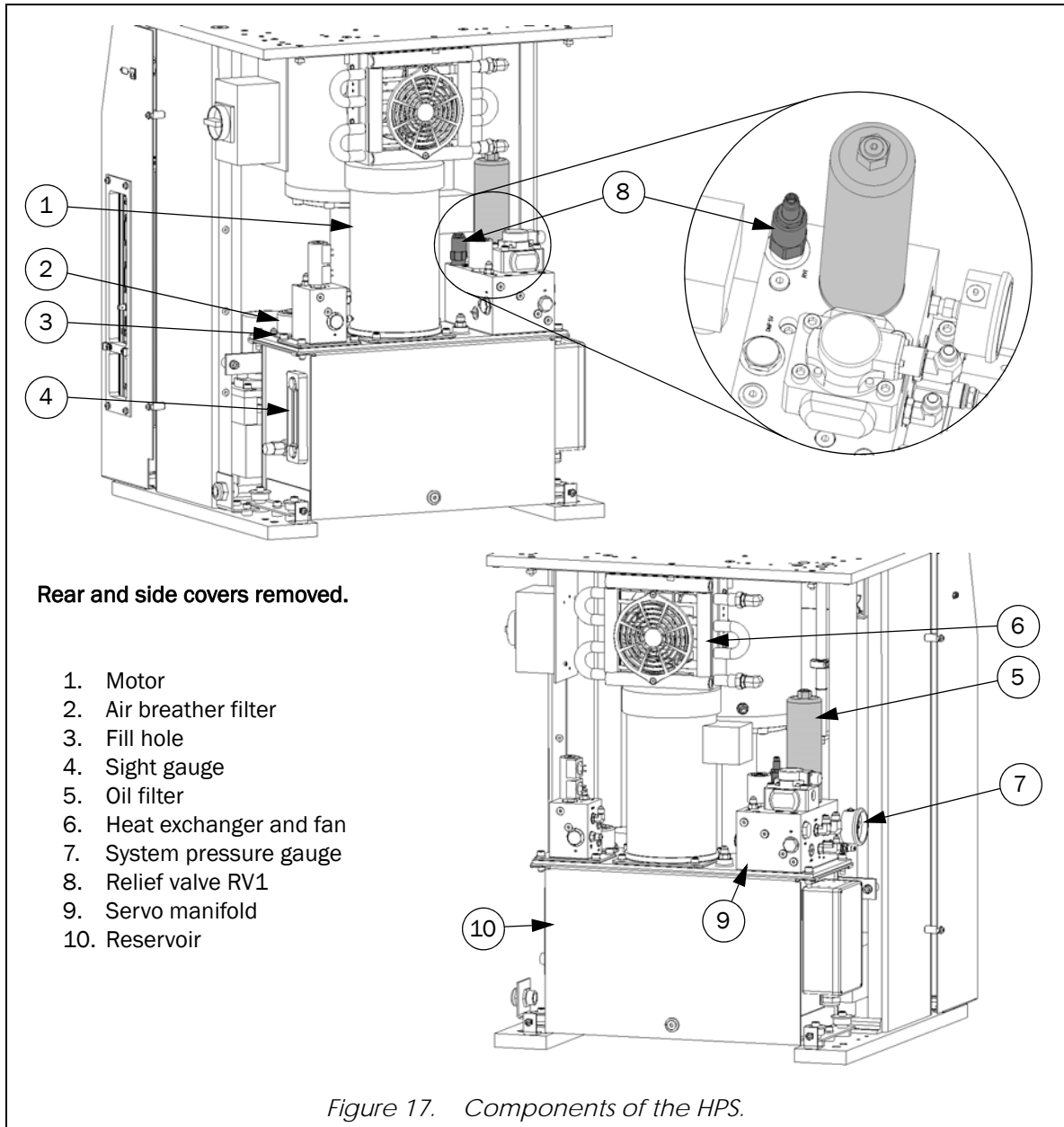

Figure 17. Components of the HPS.

that the oil is to the top of the sight gauge when the hydraulic cylinder is completely retracted. Filling the reservoir with the hydraulic cylinder slightly extended will cause overflowing of the reservoir when the hydraulic cylinder is retracted. The maximum temperature of the hydraulic oil under normal operating conditions should remain below 60 deg. C (140 deg. F), and should never exceed 80 deg. C (176 deg. F). Consult factory for operating conditions that result in oil temperatures that exceed 80 deg. C (176 deg. F). Oil temperature is monitored by a temperature switch inside the reservoir, see [“Oil temperature switch”](#) on page 41.

Air breather assembly

An air breather assembly (2, [Figure 17](#)) is placed on the reservoir’s fill hole to allow the reservoir to breathe while preventing dirt from entering the reservoir. It can be easily removed for access to the

reservoir. For maintenance of the air filter, refer to maintenance information provided in the System Operating Instructions (supplied separately).

Screen trapper

A tightly meshed screen trapper is placed in the reservoir's fill hole. This screen prevents larger debris from entering the reservoir when it is filled. Maintenance of the screen trapper should be done anytime oil is added to the reservoir, refer to maintenance information provided in the System Operating Instructions (supplied separately).

Oil temperature switch

A temperature switch is mounted in the reservoir that monitors the temperature of the oil. The switch will trip at an oil temperature of 74 +/-6 deg. C (165 +/-10 deg. F). This prevents the oil temperature from exceeding the recommended maximum temperature. The controlling software will indicate a "Motor Temp" error. Refer to [Problem No. 16](#) of [Table 5](#) on page 44.

Pump and motor

An electric motor is used to operate the pump that forces oil from the reservoir, through the high pressure hydraulic hoses and into the hydraulic cylinder. As the controller directs the frame to place load on a specimen, the HPS builds pressure in the system and the piston is actuated inside the hydraulic cylinder. Some pump and motor information is listed in [Table 3](#).

The pump is equipped with a flow control adjustment that controls the system idle pressure. Idle pressure is the pressure of the HPS when it is operating under no load conditions (i.e. when the frame is not being adjusted or performing a test). This flow control adjustment is set at the factory and should not require further adjustment. Any adjustments should only be made by an Instron service engineer.

For pump and motor maintenance, refer to the separately supplied manufacturer's information.

Table 3. HPS information.

Frame Model	Required Flow at Maximum Testing Speed	Idle Pressure	System Relief Pressure	Motor Power
300DX	3.03 Lpm (0.8 gpm)	28 bar (400 psi)	182 bar (2650 psi)	3 hp
600DX	3.33 Lpm (0.88 gpm)	28 bar (400 psi)	179 bar (2600 psi)	3 hp

Manifold assemblies

The function of any manifold is to control and route the hydraulic oil as needed to various system components. The following manifold assemblies may be present on this system (dependent on frame configuration):

- Servo manifold assembly
- Crosshead motor manifold
- Hydraulic grips manifold
- Speed control manifolds

Servo manifold assembly

A standard servo manifold (7, [Figure 17](#)) includes the following components. Refer to [Table 4](#) for the function of each component.

- A servo valve
- An oil filter
- A system pressure gauge
- A dump valve
- An idle pressure valve
- A system relief valve

Table 4. Function of components on servo manifold.

Component	Function
Servo valve:	The servo valve controls the flow of oil to the hydraulic cylinder. The position of the servo valve, which is determined by parameters entered into the controlling software by the operator, defines how the hydraulic cylinder will operate. It will either block the flow of oil to the hydraulic cylinder to hold the piston stationary, allow oil to enter the hydraulic cylinder to extend the piston, or allow oil to return to the reservoir to retract the piston.
Oil filter:	A high pressure 3-micron oil filter is mounted on the manifold to provide the necessary filtration for the high performance hydraulic components in the system. Oil passes through this filter directly after exiting the pump and before being routed to any other hydraulic component. The filter is equipped with an indicator to show when the filter is dirty and should be serviced. For maintenance of the oil filter, refer to maintenance information provided in the System Operating Instructions (supplied separately).
System pressure gauge:	A pressure gauge is located on the servo manifold so that system pressure can be monitored as needed. This pressure gauge is visible through a cut out in the left side cover of the base. System pressure is set at the factory and should not require further adjustment. Any adjustments should only be made by an Instron service engineer.
Dump valve:	When unloading the frame, the servo valve changes position to allow oil to return through the system to the reservoir. Also, the dump valve can open to allow oil to return directly to the reservoir, thus providing for a faster unload rate. The dump valve actually cycles to maintain the error signal within prescribed limits. This can cause a pulsing sound from the frame while it is unloading. This is considered normal and is not a cause for concern.
Idle pressure valve:	The idle pressure valve controls the pressure of the HPS when it is operating under no load conditions (i.e. when the frame is not being adjusted or performing a test). This valve is set at the factory and should not require further adjustment. Any adjustments should only be made by an Instron service engineer.
System relief valve:	The system relief valve provides pressure relief for the system to prevent damage to system components in the event that the pump builds too much pressure. This valve is set at the factory and should not require further adjustment. Any adjustments should only be made by an Instron service engineer.

Crosshead motor manifold

The crosshead motor manifold is located in the frame base. The manifold routes oil to the motor for the adjustable crosshead. A three-position valve in the manifold provides control of the oil flow from the manifold to the motor. The three-position valve is controlled by the operator through the crosshead up/down switch on the front panel of the frame base.

Hydraulic grips manifold

For frames equipped with G7-style crossheads, a hydraulic grips manifold is provided. The hydraulic grips manifold is located in the base of the frame. The hydraulic grips manifold contains the solenoid valves for operator control of the grip assemblies, a pressure gauge and a pressure relief valve. The pressure gauge indicates the pressure to the grip assemblies. The pressure relief valve is set at the factory and should not require further adjustment. Any adjustments should only be made by an Instron service engineer. Procedures for operation of the hydraulic grips is provided in the System Operating Instructions (supplied separately)

Speed control manifolds

For frames equipped with G7-style crossheads, two speed control manifolds are provided for the in-head grip assemblies. A speed control manifold is located on the rear of each crosshead. Each manifold includes two flow control valves that control the opening and closing speed of the grip jaws in the hydraulic grip assemblies (see [“Clamping Speed”](#) on page 33).

Pressure settings

All relief valves, reducing valves, pressure switches, etc. are set at the factory to their proper operating pressure. They should not need further adjustment. If you feel adjustment is necessary, contact your local Instron Services department as directed on page 13. Any adjustments should only be made by an Instron service engineer.

Oil cooling

An air-over-oil heat exchanger and fan (6, [Figure 17](#)) are used to cool the oil and exhaust the warm air from the console. The fan is mounted to the rear cover and has a guarded vent hole.

Troubleshooting

In the event that problems arise during operation of the system, refer to [Table 5](#) for help in determining the specific problem and its solution. If the problem cannot be determined through the chart, contact your local Instron Services department as directed on [page 13](#). Another option would be to check the listing of Frequently Asked Questions (FAQs), available on the Instron website (www.instron.com), for a description/solution to your problem.

Table 5. Troubleshooting the DX system.

No.	Possible Indications	Possible Problem	Solution
1	<ul style="list-style-type: none"> The indicators on the SERVICE display do not light when the system disconnect switch is turned on Frame power is lost for no apparent reason Test aborts and HPS shuts down Frame will not enable An interlock error message appears in the controlling software 	Frame is not receiving power	<ul style="list-style-type: none"> Check incoming power supply
		A fuse could be blown	<ul style="list-style-type: none"> Check all system fuses, refer to “Replacement of fuses” on page 52.
2	<ul style="list-style-type: none"> HPS will not start 	Always verify that: <ul style="list-style-type: none"> Computer is on Controlling software is running Frame is enabled A test procedure/method is open The load transducer is calibrated 	
		Emergency Stop engaged	Disengage Emergency Stop button, enable frame and start HPS
		System disconnect switch not ON ()	Turn the disconnect switch to ON ().
		Overload protect circuit may have tripped	For assistance, contact your local Instron Services department as directed on page 13
		Limit switch tripped	Check limits and adjust frame as necessary to reset the limit, then enable the frame and start the HPS
		If none of the above appear to be the problem: <ul style="list-style-type: none"> For Partner systems, check the Status display for any abnormal conditions or check the On-line Help for other helpful information For Bluehill systems, check the Status Log for any abnormal conditions. Click the Load Frame icon; the Status Log appears on the bottom portion of the Load Frame tab. 	

Table 5. Troubleshooting the DX system. (Continued)

No.	Possible Indications	Possible Problem	Solution
3	<ul style="list-style-type: none"> System locks up Test will not start Test aborts Software posts an error message stating that communication is lost Transducers will not calibrate Flashing single point LED on diagnostic display is not present 	Communication between frame and controls is lost.	Reset the system by performing the shutdown and startup procedures that are provided in the System Operating Instructions (supplied separately).
4	<ul style="list-style-type: none"> Test will not start Test aborts HPS shuts down Software posts an error message stating "Position Loop Failure" 	Position measurement is not working	Check the position encoder cable for damage or loose connection. If problem is not resolved, refer to Problem No. 12
		Piston is sitting at the bottom of the cylinder	Enable the frame, start the HPS and move the piston (loading unit) up approximately 6 mm (0.25 in), zero all measurements, and calibrate all transducers
5	<ul style="list-style-type: none"> Software posts an error message stating "Control Panel Watchdog Timeout" 	Communication has been lost with the user control panel	Check the user control panel cable for damage. If damage is found contact your local Instron Services department as directed on page 13 .
6	<ul style="list-style-type: none"> After opening a procedure the HPS will not start 	The frame is not enabled	Enable the frame: <ul style="list-style-type: none"> For Partner systems, select Machine and then Enable Frame For Bluehill systems, select the Frame icon and then Enable Frame
		For systems operating with Partner software, the "Enable Frame Timer" setting may be enabled	Verify the status of the "Enable Frame Timer" check box in Partner: <ol style="list-style-type: none"> Select Tools/Configure/Controllers; Controller window will open. Select the controller (59-R8) and click Modify. Be sure the "Enable Frame Timer" box is NOT checked.
7	<ul style="list-style-type: none"> For Partner systems: after starting a procedure, the live data and live graph appear on the computer monitor but the frame is not moving 	The software could be in Simulation mode	Verify that the lower right corner of the screen does not have the word "SIM". If it does, select Tools/Configure/Simulation and uncheck the "Simulate Test" box

Table 5. Troubleshooting the DX system. (Continued)

No.	Possible Indications	Possible Problem	Solution
8	<ul style="list-style-type: none"> • During a tensile test, the load reading stays steady or jerks up or down (instead of moving at a consistent rate) while position increases • Motion is visible between the specimen and a crosshead (i.e. specimen stays still while crosshead is moving or vice versa) 	<p>The specimen is slipping in the grip jaws, possibly due to:</p> <ul style="list-style-type: none"> • Specimen not seated properly • Incorrect grip jaw type for the specimen being tested • Damaged grip jaws • Improperly lubricated grip components • Insufficient initial clamping force 	<ul style="list-style-type: none"> • Unload the specimen and reclamp the grip jaws on the specimen • Determine the best grip jaw type for your specimen (refer to information provided in the System Operating Instructions (supplied separately)) • Inspect the grip jaws (refer to maintenance information provided in the System Operating Instructions (supplied separately)) • Check lubrication of grip components (refer to maintenance information provided in the System Operating Instructions (supplied separately)) • For frames with G1-style crossheads: Use additional force to clamp the grip jaws on the specimen, but DO NOT hammer grip components. • For frames with G7-style crossheads: Watch the pressure gauge on the grips manifold while clamping the specimen, it should read approximately 20.7 bar (300 psi). If it does not, or if this seems insufficient for your testing needs, contact your local Instron Services department as directed on page 13.
9	<ul style="list-style-type: none"> • During a tensile test when an extensometer is being used, no elongation is measured 	<p>The specimen is slipping in the grip jaws</p> <p>The extensometer cable could be damaged or have loose connections</p>	<p>See Problem No. 8.</p> <p>Check the extensometer cable for damage and check that connections are secure. If damage is found contact your local Instron Services department as directed on page 13.</p>
10	<ul style="list-style-type: none"> • During a tensile test, a clicking sound comes from the grip jaws • During a tensile test, a bump appears in the graph • Galling or scuffing of the grip jaws or grip pocket is observed • Bending, tearing, or scarifying of the wear plates (see example shown in Chapter 4 of the System Operating Instructions (supplied separately)). 	<p>The grip jaws are improperly lubricated</p>	<p>Unload the specimen and remove it from the grips. Relubricate grips as outlined in the System Operating Instructions (supplied separately). Assemble grip components and install specimen in grip jaws.</p>

Table 5. Troubleshooting the DX system. (Continued)

No.	Possible Indications	Possible Problem	Solution
11	<ul style="list-style-type: none"> Software posts an error message stating "Sensor Loop Failure" 	Control rate for the control mode selected is too fast	The frame should not be operated in load/stress control during the yield portion of a test. Select position or strain control and restart test, or contact your local Instron Services department as directed on page 13.
		Load cell cable could be damaged or have loose connections	Check load cell cable for damage and check that connections are secure
12	<ul style="list-style-type: none"> Position display does not change when the hydraulic cylinder is moving The hydraulic cylinder stops inadvertently during a test or during manual adjustment Software indicates a "Hard Stop" or other error for no apparent reason 	Disconnect switch not ON () or customer's power supply not ON	<ul style="list-style-type: none"> Turn the disconnect switch to ON Turn the customer's power supply to ON
		Set speed exceeds the load frame maximum speed	Reduce the set speed and enable frame
		Position encoder not functioning or damaged	Check operation of position encoder: <ol style="list-style-type: none"> 1. Enable the frame. 2. Start the HPS. 3. Manually jog the hydraulic cylinder, verify that it is moving and watch the position display to see if it reads the change in height. 4. If after 3 seconds the HPS shuts down, then the encoder is not functioning; contact your local Instron Services department as directed on page 13.
13	<ul style="list-style-type: none"> Software indicates a "Hard Stop" or other error when running a test under strain control 	Strain instrument may not be working properly	<ul style="list-style-type: none"> Check the instrument for proper operation Check that the zero pin was removed from the instrument

Table 5. Troubleshooting the DX system. (Continued)

No.	Possible Indications	Possible Problem	Solution
14	<ul style="list-style-type: none"> Adjustable crosshead has been jammed into the table and will not move. It is possible to overload the crosshead motor. If it is overloaded, oil is relieved back to the reservoir. Damage to load cell, fixtures, etc. could result. 		<p>If a specimen is gripped or the indicated load is more than 1% of frame capacity, contact your local Instron Services department as directed on page 13.</p> <p>If there is no specimen gripped and indicated load is less than 1% of frame capacity:</p> <ol style="list-style-type: none"> Turn the system disconnect switch to OFF (O). Watch movement of the compression table. If the compression table moves away from the crosshead as the piston falls, continue with next step. If the compression table does not move away from the crosshead as the piston falls, contact your local Instron Services department as directed on page 13. Inspect the frame and any installed fixtures for obvious damage. Spot check load accuracy of the system, contact your local Instron Services department as directed on page 13.
15	<ul style="list-style-type: none"> For 600DX frames, the adjustable crosshead stops moving while it is being jogged 	The adjustable crosshead limit has been tripped - the crosshead has reached the end of its travel range	Use the adjustable crosshead control switch to move the adjustable crosshead in the opposite direction. This will reset the limit switch.
16	<ul style="list-style-type: none"> The HPS shuts down Software posts a motor temperature error message 	<p>Oil temperature exceeds temperature switch setpoint, possibly due to:</p> <ul style="list-style-type: none"> Fans not operating properly Clogged air filter in base Environmental conditions exceed requirements (refer to specifications provided in the System Operating Instructions (supplied separately)) <p>Oil temperature must drop below approximately 68 deg. C (155 deg. F) to reset the switch. Once the switch has reset, the HPS can be started.</p>	<ul style="list-style-type: none"> Check for and correct fan operation Clean or replace the air filters (refer to maintenance information provided in the System Operating Instructions (supplied separately)) Correct environmental conditions

Table 5. Troubleshooting the DX system. (Continued)

No.	Possible Indications	Possible Problem	Solution
17	<ul style="list-style-type: none"> The software posts an error message like the one shown in Figure 18 	<ul style="list-style-type: none"> EFI cable could be damaged or have loose connections Communication problem between EFI and 59 Series control unit or EFI and software Incorrect version of controlling software is in use 	<ul style="list-style-type: none"> Check the cable for damage and check that connections are secure Check that the correct Ethernet crossover cable is being used Check IP settings, they should match those shown in Figure 19 Verify that the software version is 8.2a or above for Partner, or 2.15 or above for Bluehill If none of the above correct the problem, then contact your local Instron Services department as directed on page 13

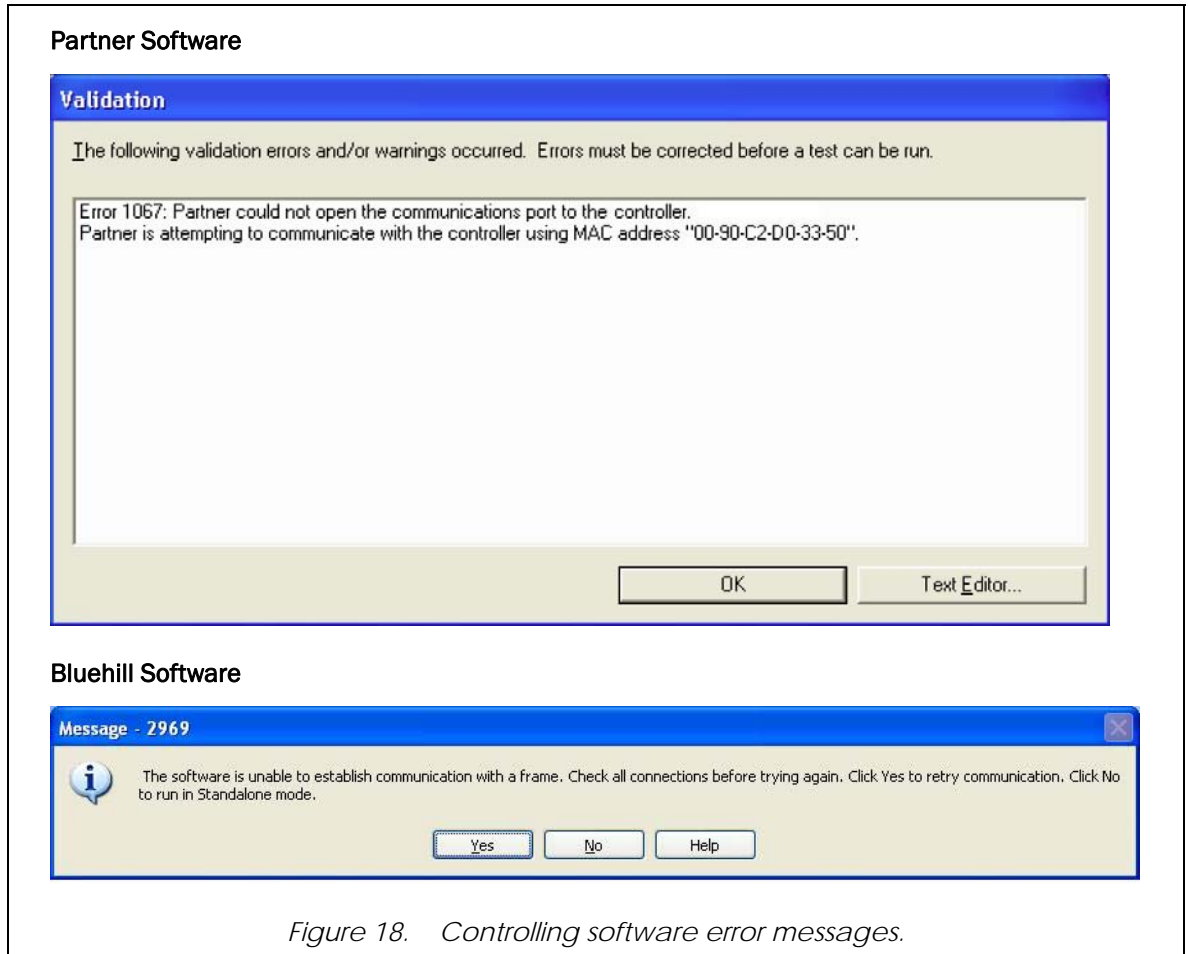

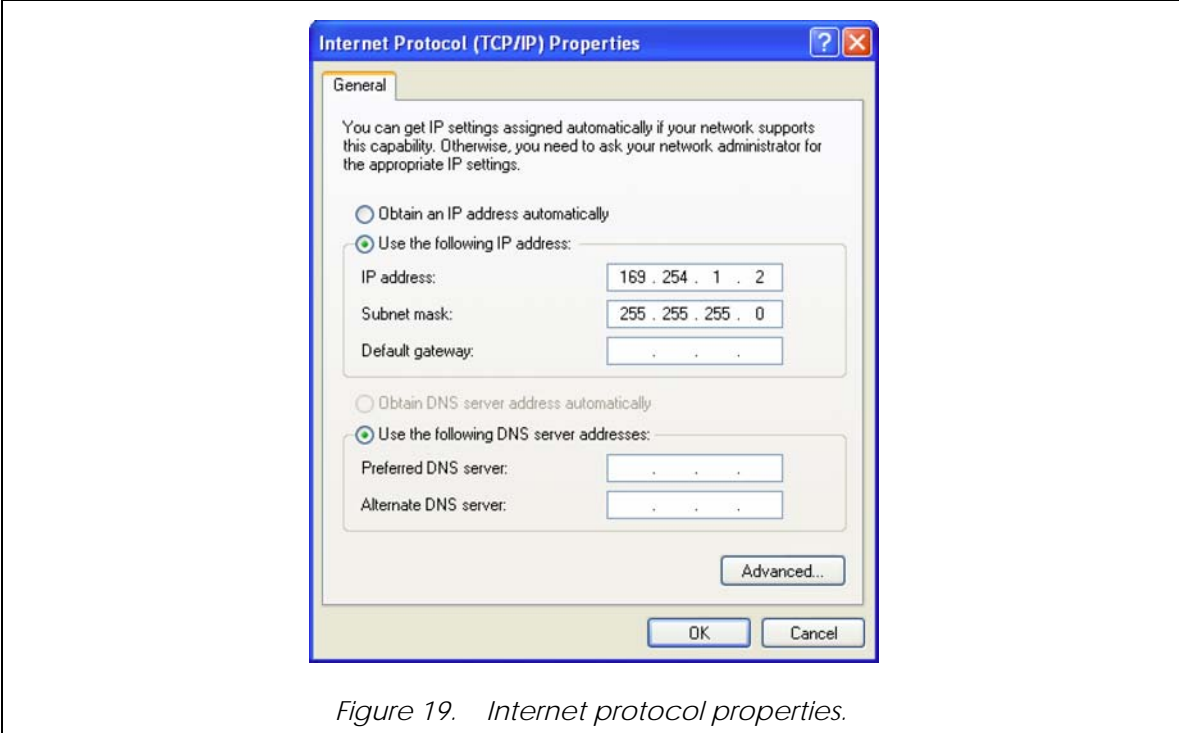

Figure 19. Internet protocol properties.

Chapter 4

Parts Replacement

• Introduction	51
• Replacement of fuses	52
• Replacement or repair of load cells	53

Introduction

DX systems require minimal parts replacement. If a part does require replacement, only the following parts can or should be replaced by the customer:

- Fuses

All other parts replacement should be done by an Instron service engineer. For assistance with replacement of any part, contact your local Instron Services department as directed on page [13](#).

Replacement of fuses

The system is equipped with fuses as outlined in [Table 6](#).

Table 6. Fuse information.

Fuse Description	Specifications	Instron Part Number	Quantity
Fuses 1FU and 2FU For 115 VAC main power supply	7 amp, 1/4D x 1-1/4LG, 250Vac (equivalent metric size is 6.3D x 32LG)	300-8905-9181	2
Fuses 1FU and 2FU For 230 VAC or 220 VAC main power supply	4 amp, 1/4D x 1-1/4LG, 250Vac (equivalent metric size is 6.3D x 32LG)	300-8905-9161	2

These fuses should only need replaced when they are blown. Problems that indicate a blown fuse are described in [Table 5](#) on page 44; refer to [Problem No. 1](#). If you believe a fuse could be blown, perform the following check to pinpoint which fuse is blown:

1. Start up the system according to the system startup procedure provided in the System Operating Instructions (supplied separately).
2. Check the indicators on the **SERVICE** display of the 59 Series control unit (see page 37), they should be lit. If the indicators are not lit, then the power supply fuse could be blown. Visually inspect the fuse. Follow the procedure outlined under "[Inspect/replace power supply fuse](#)" on page 52 to access and locate the fuse. If the fuse is blown, replace it. Information for the fuse can be found in [Table 6](#).

Inspect/replace power supply fuse

The power supply fuse is located in the electrical panel in the base of the frame. To access the fuse it is necessary to remove several covers from the base of the frame; perform the following procedure.

Equipment required

- A 4 mm hex key (supplied)

Recommended Procedure

1. Be sure the system is shut down. **All** power should be off.
2. Remove the front cover from the base of the frame, refer refer to maintenance information provided in the System Operating Instructions (supplied separately).
3. Use a 4 mm hex key to remove the six M5 button head cap screws (1, [Figure 20](#)) from the inside cover (2).
4. Remove the inside cover from the electrical panel.
5. [Figure 20](#) indicates the location of the power supply fuses (3).
6. Inspect or change the fuse as necessary. Fuse specifications are listed in [Table 6](#). Be sure to use the proper fuse size for your system's main power supply voltage.

7. Once work is complete, replace all covers.

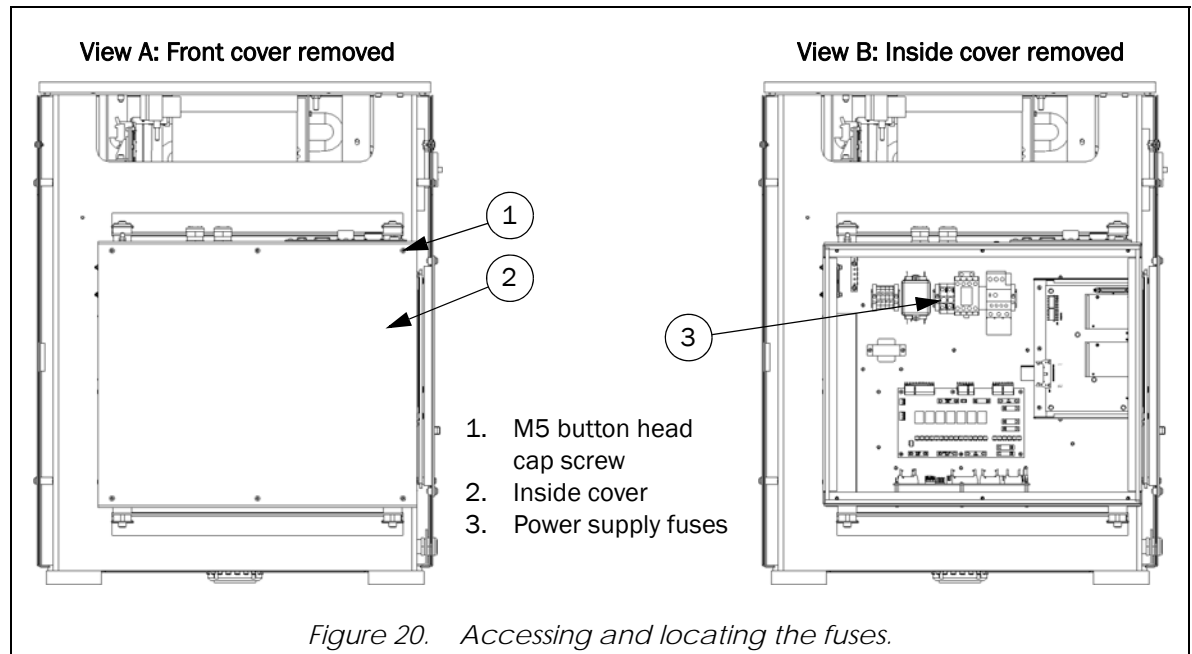

Replacement or repair of load cells

Instron load cells, in general, are electrically calibrated, self-identifying and rationalized. Approximate resistances can be provided to allow confirmation of a possible broken gauge, or a faulty connector or cable.

If a strain gauge in a cell has been badly overstressed, but still maintains its electrical continuity, the cell may show a higher than normal amount of creep. If a gauge has become improperly bonded due to degradation in use, the cell may exhibit a combination of general instability in its balance point, together with a large amount of creep. Difficulties of this sort rarely appear as an instability in the calibration of the cell.

If a load cell has been overloaded, the load-sensitive member may be permanently deformed to the extent that the proper dimensional alignments inside the cell are no longer maintained. If you suspect that a cell may be damaged, contact your local Instron Services department as directed on page 13 to arrange returning the load cell for analysis and possible repair.

This page is intentionally blank.

The background of the page is an abstract composition of soft, flowing curves in shades of light gray and white. A prominent feature is a pattern of small, light gray dots arranged in a grid, which is partially obscured by the larger, sweeping lines. The overall effect is clean, modern, and technical.

Product Support: www.instron.com