



Torsion Add-On Version 3



Operator's Guide

M10-17497-EN Revision B

Proprietary Rights Notice

This document and the information that it contains are the property of Illinois Tool Works Inc. (ITW). Rights to duplicate or otherwise copy this document and rights to disclose the document and the information that it contains to others and the right to use the information contained therein may be acquired only by written permission signed by a duly authorized officer of ITW.

Trademarks

Instron® is a registered trademark of Illinois Tool Works Inc. (ITW). Other names, logos, icons and marks identifying Instron products and services referenced herein are trademarks of ITW and may not be used without the prior written permission of ITW.

Other product and company names listed are trademarks or trade names of their respective companies.

Original Instructions

Copyright © 2020 Illinois Tool Works Inc. All rights reserved. All of the specifications shown in this document are subject to change without notice.

Worldwide Headquarters

Instron
825 University Avenue
Norwood, MA 02062-2643
United States of America

European Headquarters

Instron
Coronation Road
High Wycombe, Bucks HP12 3SY
United Kingdom

General Safety Precautions



Materials testing systems are potentially hazardous.

Materials testing involves inherent hazards from high forces, rapid motions, and stored energy. You must be aware of all moving and operating components in the testing system that are potentially hazardous, particularly force actuators or a moving crosshead.

Carefully read all relevant manuals and observe all Warnings and Cautions. The term Warning is used where a hazard may lead to injury or death. The term Caution is used where a hazard may lead to damage to equipment or to loss of data.

Instron products, to the best of its knowledge, comply with various national and international safety standards, in as much as they apply to materials and structural testing. We certify that our products comply with all relevant EU directives (CE mark).

Because of the wide range of applications with which our instruments are used, and over which we have no control, additional protection devices and operating procedures may be necessary due to specific accident prevention regulations, safety regulations, further EEA directives or locally valid regulations. The extent of our delivery regarding protective devices is defined in your initial sales quotation. We are thus free of liability in this respect.

At your request, we will gladly provide advice and quotations for additional safety devices such as protective shielding, warning signs or methods of restricting access to the equipment.

The following pages detail various general warnings that you must heed at all times while using materials testing equipment. You will find more specific Warnings and Cautions in the text whenever a potential hazard exists.

Your best safety precautions are to gain a thorough understanding of the equipment by reading your instruction manuals and to always use good judgement.

It is our strong recommendation that you should carry out your own product safety risk assessment.

Warnings



Hazard - Press the Emergency Stop button whenever you consider that an unsafe condition exists.

The Emergency Stop button removes hydraulic power or electrical drive from the testing system and brings the hazardous elements of the system to a stop as quickly as possible. It does not isolate the system from electrical power, other means are provided to disconnect the electrical supply. Whenever you consider that safety may be compromised, stop the test using the Emergency Stop button. Investigate and resolve the situation that caused the use of the Emergency Stop button before you reset it.



Flying Debris Hazard - Make sure that test specimens are installed correctly in grips or fixtures in order to eliminate stresses that can cause breakage of grip jaws or fixture components.



Incorrect installation of test specimens creates stresses in grip jaws or fixture components that can result in breakage of these components. The high energies involved can cause the broken parts to be projected forcefully some distance from the test area. Install specimens in the center of the grip jaws in line with the load path. Insert specimens into the jaws by at least the amount recommended in your grip documentation. This amount can vary between 66% to 100% insertion depth; refer to supplied instructions for your specific grips. Use any centering and alignment devices provided.



Hazard - Protect electrical cables from damage and inadvertent disconnection.

The loss of controlling and feedback signals that can result from a disconnected or damaged cable causes an open loop condition that may drive the actuator or crosshead rapidly to its extremes of motion. Protect all electrical cables, particularly transducer cables, from damage. Never route cables across the floor without protection, nor suspend cables overhead under excessive strain. Use padding to avoid chafing where cables are routed around corners or through wall openings.

Warnings



High/Low Temperature Hazard - Wear protective clothing when handling equipment at extremes of temperature.

Materials testing is often carried out at non-ambient temperatures using ovens, furnaces or cryogenic chambers. Extreme temperature means an operating temperature exceeding 60 °C (140 °F) or below 0 °C (32 °F). You must use protective clothing, such as gloves, when handling equipment at these temperatures. Display a warning notice concerning low or high temperature operation whenever temperature control equipment is in use. You should note that the hazard from extreme temperature can extend beyond the immediate area of the test.



Crush Hazard - Take care when installing or removing a specimen, assembly, structure, or load string component.

Installation or removal of a specimen, assembly, structure, or load string component involves working inside the hazard area between the grips or fixtures. When working in this area, ensure that other personnel cannot operate any of the system controls. Keep clear of the jaws of a grip or fixture at all times. Keep clear of the hazard area between the grips or fixtures during actuator or crosshead movement. Ensure that all actuator or crosshead movements necessary for installation or removal are slow and, where possible, at a low force setting.



Hazard - Do not place a testing system off-line from computer control without first ensuring that no actuator or crosshead movement will occur upon transfer to manual control.

The actuator or crosshead will immediately respond to manual control settings when the system is placed off-line from computer control. Before transferring to manual control, make sure that the control settings are such that unexpected actuator or crosshead movement cannot occur.



Robotic Motion Hazard - Keep clear of the operating envelope of a robotic device unless the device is de-activated.

The robot in an automated testing system presents a hazard because its movements are hard to predict. The robot can go instantly from a waiting state to high speed operation in several axes of motion. During system operation, keep away from the operating envelope of the robot. De-activate the robot before entering the envelope for any purpose, such as reloading the specimen magazine.

Warnings



Hazard - Set the appropriate limits before performing loop tuning or running waveforms or tests.

Operational limits are included within your testing system to suspend motion or shut off the system when upper and/or lower bounds of actuator or crosshead travel, or force or strain, are reached during testing. Correct setting of operational limits by the operator, prior to testing, will reduce the risk of damage to test article and system and associated hazard to the operator.



Electrical Hazard - Disconnect the electrical power supply before removing the covers to electrical equipment.

Disconnect equipment from the electrical power supply before removing any electrical safety covers or replacing fuses. Do not reconnect the power source while the covers are removed. Refit covers as soon as possible.



Rotating Machinery Hazard - Disconnect power supplies before removing the covers to rotating machinery.

Disconnect equipment from all power supplies before removing any cover which gives access to rotating machinery. Do not reconnect any power supply while the covers are removed unless you are specifically instructed to do so in the manual. If the equipment needs to be operated to perform maintenance tasks with the covers removed, ensure that all loose clothing, long hair, etc. is tied back. Refit covers as soon as possible.



Hazard - Shut down the hydraulic power supply and discharge hydraulic pressure before disconnection of any hydraulic fluid coupling.

Do not disconnect any hydraulic coupling without first shutting down the hydraulic power supply and discharging stored pressure to zero. Tie down or otherwise secure all pressurized hoses to prevent movement during system operation and to prevent the hose from whipping about in the event of a rupture.



Hazard - Shut off the supply of compressed gas and discharge residual gas pressure before you disconnect any compressed gas coupling.

Do not release gas connections without first disconnecting the gas supply and discharging any residual pressure to zero.

Warnings



Explosion Hazard - Wear eye protection and use protective shields or screens whenever any possibility exists of a hazard from the failure of a specimen, assembly or structure under test.



Wear eye protection and use protective shields or screens whenever a risk of injury to operators and observers exists from the failure of a test specimen, assembly or structure, particularly where explosive disintegration may occur. Due to the wide range of specimen materials, assemblies or structures that may be tested, any hazard resulting from the failure of a test specimen, assembly or structure is entirely the responsibility of the owner and the user of the equipment.



Hazard - Ensure components of the load string are correctly pre-loaded to minimize the risk of fatigue failure.

Dynamic systems, especially where load reversals through zero are occurring, are at risk of fatigue cracks developing if components of the load string are not correctly pre-loaded to one another. Apply the specified torque to all load string fasteners and the correct setting to wedge washers or spiral washers. Visually inspect highly stressed components such as grips and threaded adapters prior to every fatigue test for signs of wear or fatigue damage.

Table of Contents

Chapter 1: Introduction	11
Overview	11
System components	12
Specifications	16
Residual risks and safe operation	17
Chapter 2: Function of Controls	19
Torsion lock function	19
Torsion controller assembly	20
Indicators	20
Torsion-specific software controls	21
Torsion Settings	23
Torsion-specific handset controls	23
Manual rotational jog	25
Chapter 3: Testing	27
Start the system	27
Set up the rotation transducer	28
Testing notes	28
Rotational crosshead alignment for axial testing	29

Chapter 1

Introduction

• Overview.....	11
• System components	12
• Specifications	16
• Residual risks and safe operation	17

These instructions should be read in conjunction with the Operator's Guide for the standard 6800 testing system.

The Operator's Guide includes information about risk reduction and safe use of the system, function of controls and basic operation.

These instructions contain only information that is specific to the system when the Torsion Add-On accessory is added to it.

Overview

The Torsion Add-On system comprises:

- a compatible electromechanical load frame, e.g. 6800 Series
- a secondary motor mounted to the moving crosshead
- a torsion controller assembly mounted to the column of the load frame
- a suitable biaxial load cell mounted to the base adapter

This configuration provides torque to the specimen which allows biaxial testing of specimens.

System components

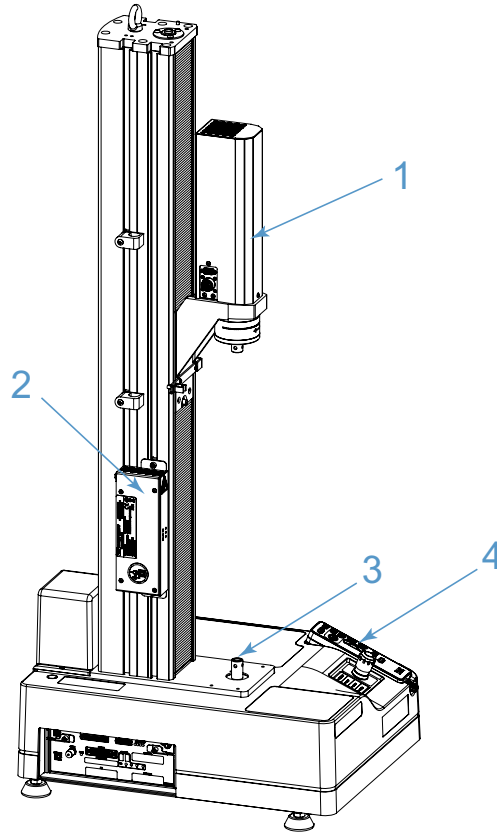

Figure 1. Torsion Add-On components on a single-column system

Legend for [Figure 1](#) and [Figure 2](#)

Label	Component	Description
1	Torsion drive assembly	This assembly contains the motor, gearbox, shaft coupling, bearing housing and drive shaft. These combine to produce rotation for biaxial testing.

Label	Component	Description
2	Torsion controller assembly	This enclosure contains the electronics required to drive the torsion motor and provide rotational feedback to the testing software. The front panel contains three LEDs. All three LEDs must be illuminated green for testing to begin. Refer to " Torsion controller assembly " on page 20 for more details.
3	Biaxial base mounting	Refer to the installation instructions supplied with the biaxial base mounting.
4	Torsion-specific handset	See Figure 3 on page 15.
5	Extended travel top plate	Dual column frames only (Figure 2). The top plate is adapted to allow the torsion drive assembly to move through it. This means that the overall effective height of the frame is increased (refer to " Specifications " on page 16).

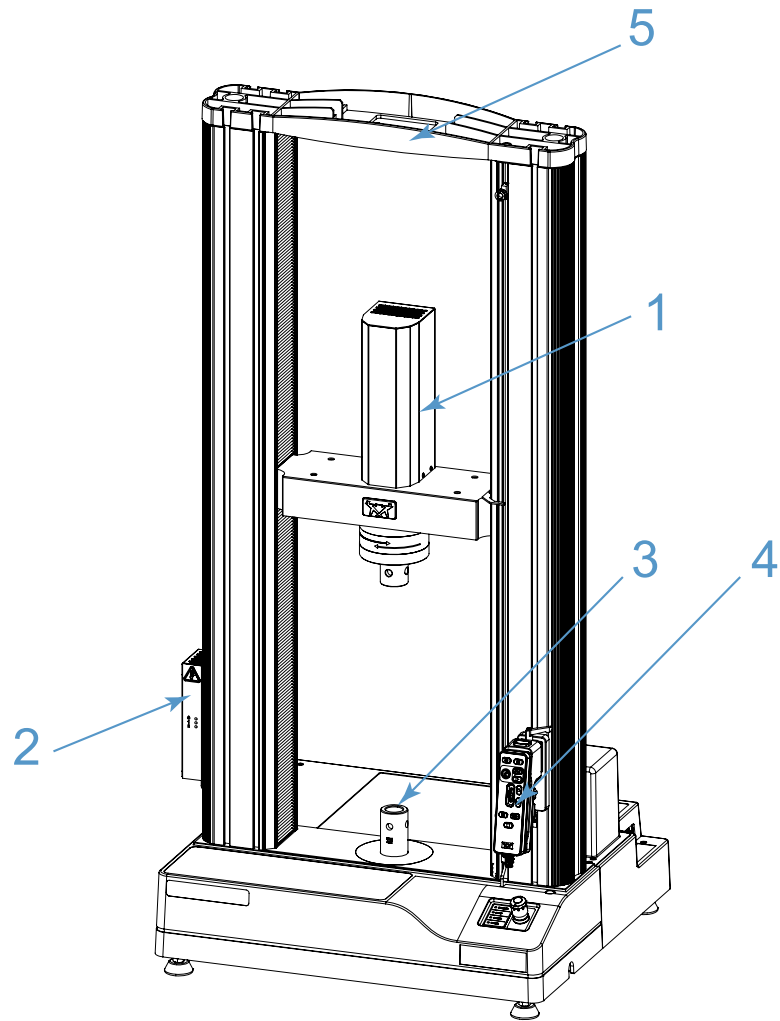

Figure 2. Torsion Add-On components on a dual column system

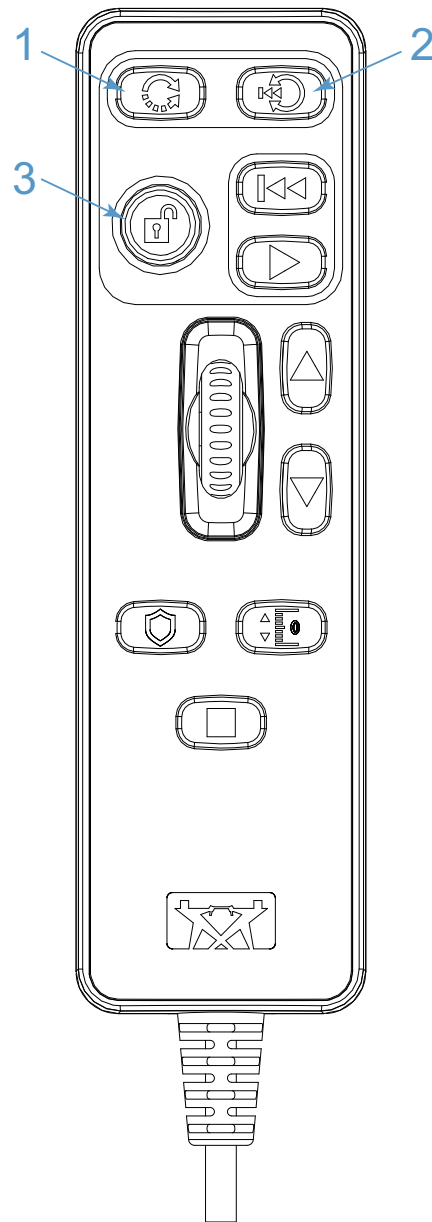

Figure 3. Torsion-specific handset

Legend for Figure 3

Label	Function
1	ROTATE

Label	Function
2	ROTATE TO ZERO
3	UNLOCK

For a full description of the function of these buttons, refer to [“Torsion-specific handset controls”](#) on page 23.

Specifications

Table 1. General Specifications

Parameter	Single column frames	Dual column frames
Maximum axial load - no torque (kN)	5	50
Maximum axial load - with torque (kN)	5	25
Maximum torque output at 40 rpm (N-m)	20	
Maximum torque output at 80 rpm (N-m)	10	
Maximum test rotation speed (rpm)	80	
Maximum power (VA)	280	
Single Phase Voltage (Vac) ($\pm 10\%$)	110 - 240	
Electrical Frequency(Hz)	47 - 63	

Table 2. Frame height increases due to torsion drive assembly

Frame Model	Maximum height of standard frame mm (in)	Maximum height of frame with Torsion Add-On mm(in)
68SC05	1015 (40.0)	1293 (51.0)
68SC1	1412 (55.6)	1675 (66.0)
68SC2	1412 (55.6)	1675 (66.0)

Table 2. Frame height increases due to torsion drive assembly (Continued)

Frame Model	Maximum height of standard frame mm (in)	Maximum height of frame with Torsion Add-On mm(in)
68SC5	1412 (55.6)	1675 (66.0)
68SC5 extra height	1682 (66.2)	1932 (76.0)
68TM5	1638 (64.5)	1826 (71.9)
68TM5 extra height	2163 (85.2)	2330 (91.7)
68TM10	1638 (64.5)	1826 (71.9)
68TM10 extra height	2163 (85.2)	2330 (91.7)
68TM30	1638 (64.5)	1826 (71.9)
68TM30 extra height	2163 (85.2)	2330 (91.7)
68TM50	1638 (64.5)	1826 (71.9)
68TM50 extra height	2163 (85.2)	2330 (91.7)

Residual risks and safe operation

The residual risks described in this section are in addition to those described in the Operator's Guide for the standard 6800 testing system.

Warning



Pinch hazard between rotating upper grip and frame columns.

The rotation of the load string introduces an additional hazard, especially if the space between any test fixture and the frame columns is small.

Warning



Entanglement hazard - keep hair and loose clothing away from the rotating test fixture

Warning



Stored energy hazard - remove any torque from a specimen before unlocking the torsion drive.

Remove any torque to prevent unexpected rotation when the torsion drive is unlocked.

Warning



Crush hazard between the torsion drive assembly and the top plate of the load frame.

Be aware that the torsion drive assembly can move through the top plate with the potential to crush any object in its path.

Warning



Extended frame height due to extended travel top plate.

Be aware that the torsion drive assembly can move through the top plate, extending the height required for safe operation of the testing system (refer to "[Specifications](#)" on page 16 for details).

Chapter 2

Function of Controls

• Torsion lock function	19
• Torsion controller assembly	20
• Indicators	20
• Torsion-specific software controls	21
• Torsion Settings	23
• Torsion-specific handset controls	23
• Manual rotational jog	25

Torsion lock function

The default condition for the torsion drive is locked.

The testing system will unlock the torsion drive in the following situations:

- Rotate using the **UNLOCK** and **ROTATE** buttons on the handset
- Rotate to zero using the **UNLOCK** and **ROTATE TO ZERO** buttons on the handset
- Move to angle (initiated by a softkey function) using the **UNLOCK** and **ROTATE TO ZERO** buttons on the handset
- Start a test

For each of these situations, the torsion drive is locked when the action is completed.

You can temporarily unlock the torsion drive in order to manually position the torsion drive (for axial alignment, for example) using the **Toggle torsion lock** function (refer to “[Manual rotational jog](#)” on page 25).

Torsion controller assembly

The display panel on the front of the controller consists of 3 green LEDs, as shown in [Figure 4](#) on page 20.

All three LEDs must be illuminated green for motor powered rotary motion. This includes jogging, returning to zero or running a test.

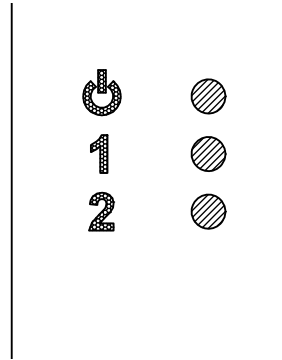

Figure 4. LED display

LED	Description
Power	Illuminated when there is power to the controller and it is switched on.
1	Illuminated when the status of the torsion lock is unlocked (refer to " Torsion lock function " on page 19).
2	Illuminated when the torsion drive is able to provide rotary motion by rotating the motor. If the LED is off the rotary drive is disabled and unable to provide rotary motion.

Indicators

The system uses certain conventions to display the direction of movement of the torsion drive. These conventions apply to both hardware and software.

- **Lines and arrows**

Solid indicates clockwise movement, dashed indicates counter-clockwise movement (see [Figure 5](#) on page 21).

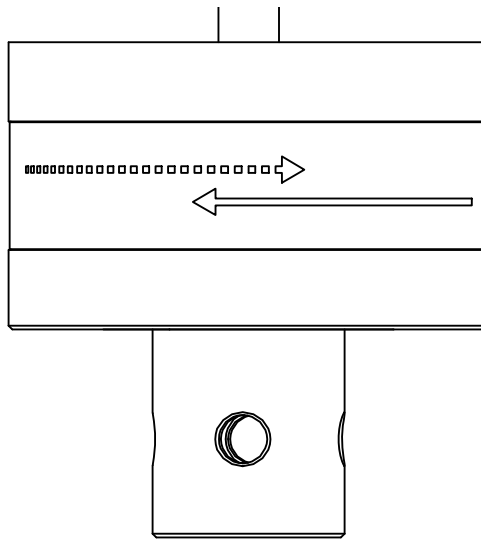

Figure 5. Direction indicator on torsion drive

- **LED indicators and software colored objects**

Solid illumination indicates clockwise movement, blinking illumination indicates counter-clockwise movement.

Torsion-specific software controls

The software provides the following controls for the torsion transducer in the Settings section of the rotation transducer dialog box:

- **Balance**

Establish the zero rotation point.

Setting the zero rotation point sets the transducer value to zero. This identifies the current position as the starting point from which total rotation is measured during a test.

- **Rotate to zero**

Rotate the torsion drive back to the zero rotation point. The direction the system rotates depends on the current rotation value. When the current value is above zero

the system rotates counter-clockwise. When the current value is below zero the system rotates clockwise.

The system will never rotate more than one full rotation. If the rotation value exceeds $\pm 360^\circ$, the system rotates to the zero rotation point and sets the rotation value to zero.

Some examples are:

- System currently at $+200^\circ$. Rotate to zero will rotate counterclockwise to zero and balance the rotation (set 0° to 0°).
- System currently at $+700^\circ$. Rotate to zero will rotate counterclockwise to $+360^\circ$ and balance the rotation (set $+360^\circ$ to 0°).
- System currently at -500° . Rotate to zero will rotate clockwise to -360° and balance the rotation (set -360° to 0°).



*This action is dependent upon the **Override point of control** settings under **Operator Protection** on the **Admin** tab. When **Start test and return** is set to **Frame controls**, you must use the handset to initiate the return to the zero point. When **Start test and return** is set to **Remote**, you must use the software to initiate the return to the zero point.*

- **Stop rotation**

Stop the rotation, if necessary. For example, if the **Rotate to zero** button was used in error and you need to stop the rotation.



*The **STOP** button on the handset also stops the rotation.*

- **Reverse rotary jog**

Reverse the direction of the torsion drive when the rotary jog controls are activated.

When this button is used, the system updates the Jog direction displayed under Settings (refer to "[Torsion Settings](#)" on page 23).

- **Toggle torsion lock**

Alternate the torsion drive lock between locked and unlocked.

When this button is used, the system updates the Torsion lock status displayed under Settings (refer to "[Torsion Settings](#)" on page 23).

Warning



Remove any torque before unlocking the torsion drive.

This prevents unexpected rotation.

Torsion Settings

The software displays information about the torsion transducer in the Settings section of the rotation transducer dialog box as follows:

- Jog direction - clockwise or counter-clockwise.

This displays the direction the actuator will rotate if the rotary jog function is activated.

- Torsion lock - locked or unlocked.

The default condition is locked. When the torsion drive is locked, you can only rotate the upper grip using the rotary jog function. When you use the **Toggle torsion lock** button to unlock the torsion drive, you can rotate the upper grip freely by hand.

Refer to "[Torsion lock function](#)" on page 19 for more information.

Torsion-specific handset controls

The two buttons at the top of the handset are torsion-specific. **ROTATE** (1) and **ROTATE TO ZERO** (2) operate together with **UNLOCK** (3). Refer to the 6800 Operator's Guide for full details of the operation of the **UNLOCK** button combined with other functions on the handset.

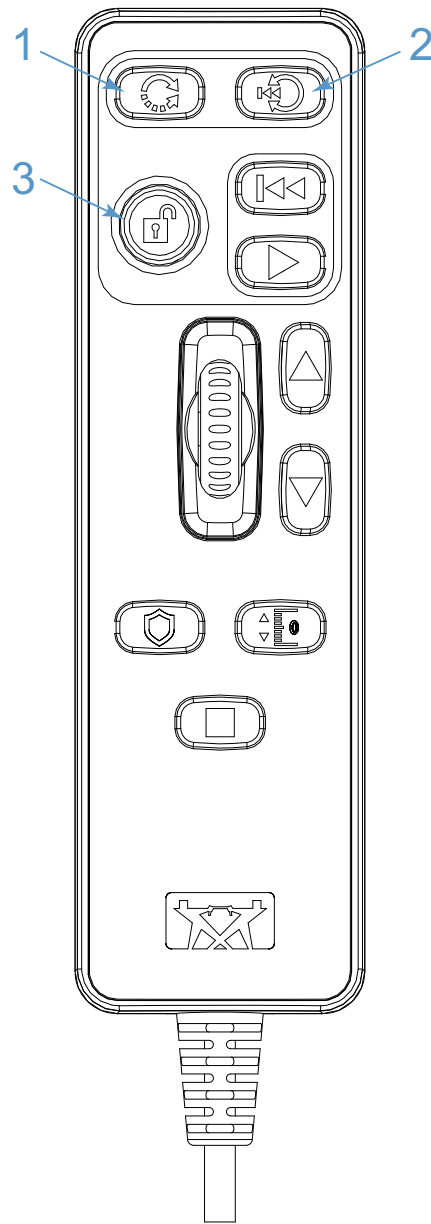

Figure 6. Torsion-specific handset

- **ROTATE**

Press the **UNLOCK** button followed by this button to rotate the torsion drive in the direction specified in the software.

Press and hold the button to move at a speed of 4 rpm.

The label on the torsion drive shows that clockwise motion is indicated by solid lines and counterclockwise motion is indicated by dashed lines. Similarly any LED indicators illuminate in solid color for clockwise motion and blinking color for counterclockwise motion. Refer to “[Indicators](#)” on page 20.

- **ROTATE TO ZERO**

Press the **UNLOCK** button followed by this button to rotate the torsion drive back to the zero rotation point. The direction the system rotates depends on the current rotation value. When the current value is above zero the system rotates counterclockwise. When the current value is below zero the system rotates clockwise.

The system will never rotate more than one full rotation. If the rotation value exceeds $\pm 360^\circ$, the system rotates to the zero rotation point and sets the rotation value to zero.

- System currently at $+200^\circ$. Rotate to zero will rotate counterclockwise to zero and balance the rotation (set 0° to 0°).
- System currently at $+700^\circ$. Rotate to zero will rotate counterclockwise to $+360^\circ$ and balance the rotation (set $+360^\circ$ to 0°).
- System currently at -500° . Rotate to zero will rotate clockwise to -360° and balance the rotation (set -360° to 0°).



*This action is dependent upon the **Override point of control** settings under **Operator Protection** on the **Admin** tab. When **Start test and return** is set to **Frame controls**, you must use the handset to initiate the return to the zero point. When **Start test and return** is set to **Remote**, you must use the software to initiate the return to the zero point.*

The remaining controls on the handset operate in the same way as a standard 6800 testing system.

Manual rotational jog



If you need to rotate the test fixture manually, to install and align a test fixture for example, you can unlock the torsion drive in the software and position the load string manually.

Warning



Remove any torque before unlocking the torsion drive.

This prevents unexpected rotation.

1. Make sure that no specimen is installed.
2. Select  in the Console area to open System Details.
3. Select  in the System Settings area to open the Transducer dialog for rotation.
4. Select the **Toggle torsion lock** button to unlock the torsion drive.
5. Rotate the load string manually to the desired position.
6. Close the Transducer dialog.

Chapter 3

Testing

• Start the system	27
• Set up the rotation transducer	28
• Testing notes	28
• Rotational crosshead alignment for axial testing	29

Start the system

Verify that all the devices are connected and that all connections are secure.

The biaxial load cell requires the following connections:

- axial channel on load cell connected to **FORCE** connector on the controller
 - torque channel on load cell connected to **STRAIN 2** connector on the controller
1. Connect the external power to the system.
 2. Turn the switch on the back of the torsion controller assembly to on.

Warning





Do not connect or disconnect the power cable from the torsion controller assembly when the unit is switched on.

3. Turn on the computer that will run Bluehill[®] software.
4. Turn on power to the load frame.
5. Make sure that the appropriate travel limits are set (refer to the Operator's Guide for the standard 6800 testing system)
6. Start Bluehill[®] software.
7. Calibrate and balance all transducers in Bluehill[®]. This includes displacement, load and torque transducers.

You can now proceed to set up the rotation transducer (refer to [“Set up the rotation transducer”](#) on page 28).

Set up the rotation transducer

1. Make sure that no specimen is installed.
2. Select  in the Console area to open System Details.
3. Select  in the System Settings area to open the Transducer dialog for rotation.
4. Under Settings, select the transducer configuration in the **Transducer configuration** field.
5. Use the **ROTATE** button on the handset to position the transducer for testing.



*The direction of rotation when pressing the **ROTATE** button is set in the software to **Clockwise** or **Counter-clockwise**.*

6. When the transducer is positioned for testing, select the **Balance** button.
The system sets the current transducer value to zero.

The rotation transducer is now ready to install a specimen.

Full details on all testing procedures and reference information is in the Bluehill® online Help and Reference.

Testing notes

Tests using the Torsion Add-On require one of the following test method types in Bluehill®:

- Tension/Torsion Profiler
- Compression/Torsion Profiler

When setting up Test Control, note the following:



- upper section contains parameters for axial motion - set to **Hold** if you want rotation motion only for your test

- lower section contains parameters for rotation motion - you can set absolute rotation to a specific angle or you can set a relative rotation using the delta measurement feature.
- the test method should use multiple end of test criteria. For example, if you want the test to end when the specimen breaks but you do not expect the rotation to exceed 180° then you should set two criteria, one for specimen break and another for a rotation of 180°.

Full details on all testing procedures and reference information is in the Bluehill® online Help and Reference.

Rotational crosshead alignment for axial testing

The system can be used for axial-only testing and it should be aligned axially using the alignment fixture provided.

1. Make sure that no specimen is installed.
2. Install the alignment fixture in the top of the load string, securing it with the clevis pin provided.
3. Carefully jog the crosshead downwards until the bottom of the alignment bar is engaged in the base adapter.
4. Select  in the Console area to open System Details.
5. Select  in the System Settings area to open the Transducer dialog for rotation.
6. Select the **Toggle torsion lock** button to unlock the torsion drive.
7. Manually rotate the alignment fixture until the holes line up with those in the base adapter and secure the bottom of the bar with the clevis pin provided.
8. Tighten the lock nuts on each end of the load string.
9. Select the **Toggle torsion lock** button to lock the torsion drive.
10. Select **Balance** to balance the rotation transducer.
11. Remove the alignment bar.

The system is ready for axial testing and the torsion motor drive will hold its position as long as the torsion controller assembly is powered up.



www.instron.com