

2710-100 Series | Screw Side-Action Grips

Screw side-action grips provide a very simple and efficient method for holding test specimens in a wide range of applications. The dual - acting design of 2710-100 series grips means that jaw faces can be adjusted to accommodate different specimen thicknesses. This ensures that the line of tensile force remains concentric with the grip body. They can be equipped with a selection of interchangeable grip jaw faces in various sizes and choice of surfaces including smooth ground, rubber-coated and serrated. Line contact and special coated faces are also available.

Jaw faces can be changed single-handedly in seconds without the use of tools or pins.

Features and Benefits

- Range of capacities from 100 N, 500 N, 1 kN, 2 kN, 5 kN, 10 kN
- Wide range of specimen thicknesses up to 46 mm (1.8 in)
- Jaw faces can be changed in seconds with a slide in/out action
- Variety of jaw face sizes and surfaces
- Dual-action independent clamps allow total control of specimen location
- Open-fronted design for ease-of-specimen insertion
- Self-aligning jaw faces compensate for specimen irregularities
- Optional specimen centering device for accurate specimen alignment
- Temperature range: -70 °C to +125 °C (-94 °F to +257 °F)
2710-116: -70 °C to 200 °C (-94 °F to 392 °F)

Application Range

- Static tensile tests on a wide range of materials and specimen types including plastics, metals, textiles, paper, thin sheet, foil and wire
- Type of loading: Tensile, static and tension-tension cyclic tests. Not suitable for high cycle dynamic fatigue tests
- Specimen shapes: Round (wires) and flat specimens with or without shoulder

Principle of Operation

2710-100 Series screw side-action grips are designed for static tensile testing and include a number of features to optimize functionality and ease-of-use.

The dual-acting screw design accommodates specimens up to 46 mm (1.8 in) thick and can be offset for irregular or asymmetrical specimens such as lap-shear types.

Screw knobs on either side are knurled to facilitate hand tightening and the higher capacities also feature hex socket screw knobs that accommodate a hex key or torque wrench.

Jaw faces can be changed single-handedly in seconds without the use of tools or pins. The grips can be left on the system and there are no loose items to misplace.

Engraved scales on the carriages aid in centering the planes of gripping. Further improvements in specimen alignment can be gained by using the optional specimen centering device.

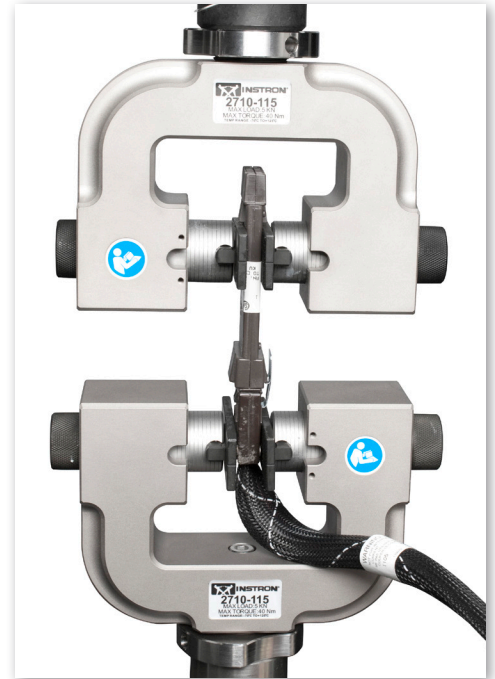

5 kN Screw Side Action Grips

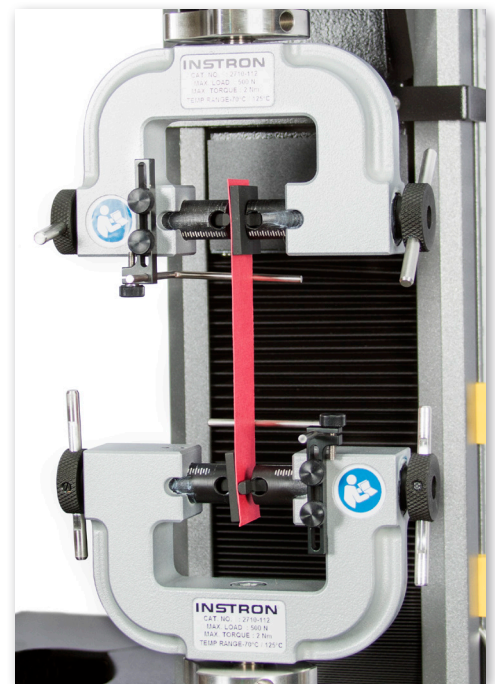

500 N Screw Side Action Grips

Specifications

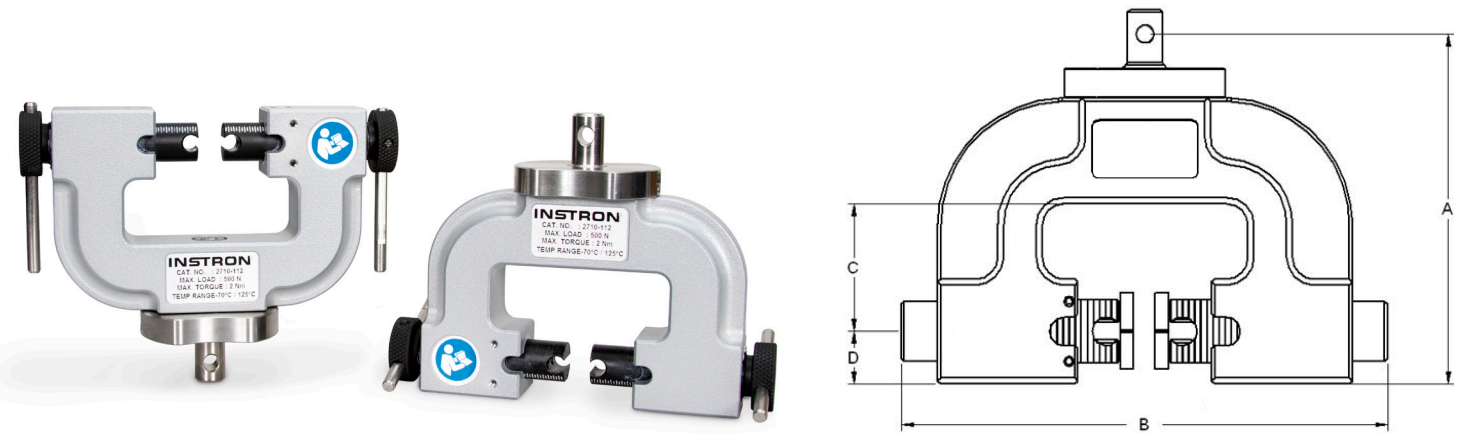

Catalog Number	Capacity			Lower and Upper Fitting	Effective Upper Length (A)		Effective Lower Length (A)		Overall Width (B)		Throat Depth (C)		Throat Depth (D)		Weight (per grip)	
	kN	kgf	lbf		mm	in	mm	in	mm	in	mm	in	mm	in	kg	lb
2710-111	0.1	10	22	6 mm clevis pin (Type Om)	94	3.68	93.5	3.68	173	6.8	37.5	1.48	12.5	0.49	0.635	1.4
2710-112	0.5	50	122	6 mm clevis pin (Type Om)	98.6	3.86	98	3.68	173	6.8	42.5	1.67	12.5	0.49	0.748	1.65
2710-113	1	100	225	6 mm clevis pin (Type Om)	116.5	4.6	116.5	4.6	196	4.57	42.5	1.7	17.5	0.7	1.15	2.54
2710-114	2	200	450	6 mm clevis pin (Type Om)	116.5	4.6	116.5	4.6	196	4.57	42	1.7	17.5	0.7	1.15	2.54
2710-115	5	500	1125	1/2 in (Type D)	155.5	6.1	155.5	6.1	225	8.86	55	2.2	25	1.0	2.68	5.91
2710-116	10	1000	2250	1/2 in (Type D)	155.5	6.1	155.5	6.1	225	8.86	55	2.2	25	1.0	4.91	10.82

Common Specifications

Temperature Range: -70 °C to +125 °C (-94 °F to +257 °F), 2710-116: -70 °C to 200 °C (-94 °F to 392 °F)

Operating Principal: Dual side action screw design with offsettable jaw face position

Maximum Specimen Thickness with Flat Faces: Up to 46 mm (1.8 in)

For a single upper grip use 2710-111U, 2710-112U, 2710-113U, 2710-114U, 2710-115U, or 2710-116U

Other Optional Items for Use With 2710-100 Series Screw Side-Action Grips

2501-254	Adaptor - 6 mm clevis pin (Type Om) interface For use with 2710-100 and 200 series screw side-action grips to change standard upper/lower fitting
2501-251	Adaptor - 1/2 in clevis pin (Type Dm) interface For use with 2710-100 and 200 series screw side-action grips to change standard upper/lower fitting
2710-109	Specimen centering device

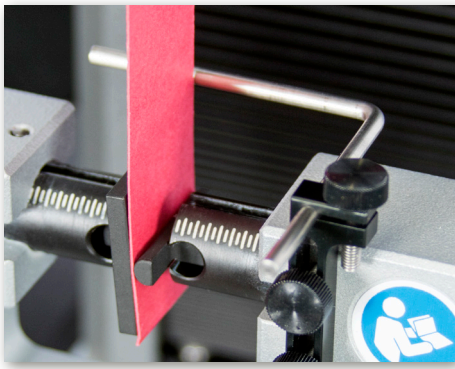

Optional specimen centering device



Slide on and off Jaw Face design

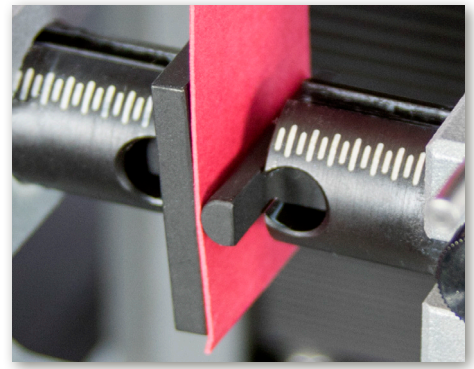

Graduations to aid in offset adjustments.

Grip Face Options for 2710-111 and 2710-112

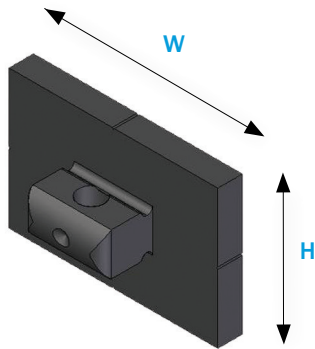

Catalog Number	Surface	Face Width	Face Height	Maximum Specimen Thickness	Weight per Face
		mm	mm		
2702-360	Rubber	10	10	34	2.96
2702-361	Rubber	12	25	34	9.22
2702-362	Rubber	25	25	34	18.44
2702-363	Rubber	50	25	34	36.95
2702-364	Rubber	100	25	34	73.86
2702-365	Serrated	10	10	35	2.40
2702-366	Serrated	12	25	35	7.70
2702-367	Serrated	25	25	35	15.3
2702-368	Serrated	50	25	35	30.60
2702-369	Serrated	100	25	35	61
2702-370	Smooth	10	10	35	2.40
2702-371	Smooth	12	25	35	7.70
2702-372	Smooth	25	25	35	15.3
2702-373	Smooth	50	25	35	30.6
2702-374	Smooth	100	25	35	61
2702-375	Brake-Lining (HFC)	25	25	34	19
2702-376	Brake-Lining (HFC)	50	25	34	37
2702-377	Line-Contact/Smooth	25	25	35	3.99/15.3

Notes:

1. Catalog number provides four faces.
2. Surfaces are hardened to 55 Rc (excluding rubber and brake lining surfaces)
3. Line contact faces are provided with a smooth-ground



Line Contact

For gripping paper and elasticated fabrics.



Brake Lining

For gripping composite tows and other hard, but easily damaged, materials.



Serrated

For gripping plastics, metals, fabric, and soft materials, such as elastomers.



Rubber

For gripping threads, fabrics, plastic tapes, and materials where a compliant surface is beneficial.



Wave Profile

For gripping coated fabrics, tough foils, and engineering textiles.



Smooth

For gripping films, foils, fine wires, thin sheets, and tapes.



Vee Serrated

For gripping larger diameter rounds, such as thicker metal wires, tubes, and hard plastic.

Grip Face Options for 2710-113,114,115, and 116

Catalog Number	Surface	Face Width	Face Height	Maximum Specimen Thickness	
		mm	mm	2710-113/114	2710-115/116
2702-300	Rubber	25	25	34	44
2702-301	Rubber	25	38	34	44
2702-302	Rubber	25	50	34	44
2702-303	Rubber	38	13	34	44
2702-304	Rubber	38	25	34	44
2702-305	Rubber	38	50	34	44
2702-306	Rubber	50	25	34	44
2702-307	Rubber	50	38	34	44
2702-308	Rubber	50	50	34	44
2702-309	Rubber	75	25	34	44
2702-310	Rubber	75	50	29	39
2702-311	Rubber	150	50	29	39
2702-315	Serrated	25	25	36	46
2702-316	Serrated	25	38	36	46
2702-357	Serrated	25	50	31	41
2702-318	Serrated	38	13	36	46
2702-319	Serrated	38	25	36	46
2702-320	Serrated	38	50	36	46
2702-321	Serrated	50	25	36	46
2702-322	Serrated	50	38	36	46
2702-323	Serrated	50	50	36	46
2702-324	Serrated	75	25	36	46
2702-325	Serrated	75	50	31	41
2702-326	Serrated	150	50	31	41
2702-330	Smooth	25	25	36	46
2702-331	Smooth	25	38	36	46
2702-332	Smooth	25	50	36	46
2702-333	Smooth	38	13	36	46
2702-334	Smooth	38	25	36	46
2702-335	Smooth	38	50	36	46
2702-336	Smooth	50	25	36	46
2702-337	Smooth	50	38	36	46
2702-338	Smooth	50	50	36	46
2702-339	Smooth	75	25	36	46
2702-340	Smooth	75	50	31	41
2702-341	Smooth	150	50	31	41
2702-345	Brake Lining (HFC)	25	38	33	43
2702-346	Brake Lining (HFC)	38	25	33	43
2702-347	Brake Lining (HFC)	50	38	33	43
2702-350	Line-Contact	25	N/A	36	46
2702-351	Line-Contact	75	N/A	14	24
2702-352	Wave	50	50	22.5	32.5
2702-353	Wave	75	50	N/A	5
2702-354	Vee	3 - 6.5	25	6.5	6.5
2702-355	Vee	6 - 18.5	25	18.5	18.5

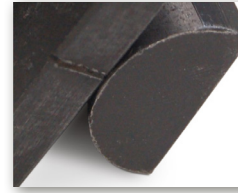

Line Contact
For gripping paper and elasticated fabrics.



Brake Lining
For gripping composite tows and other hard, but easily damaged, materials.



Serrated
For gripping plastics, metals, fabric, and soft materials, such as elastomers.



Rubber
For gripping threads, fabrics, plastic tapes, and materials where a compliant surface is beneficial.



Wave Profile
For gripping coated fabrics, tough foils, and engineering textiles.



Smooth
For gripping films, foils, fine wires, thin sheets, and tapes.



Vee Serrated
For gripping larger diameter rounds, such as thicker metal wires, tubes, and hard plastic.

www.instron.com



Worldwide Headquarters
825 University Ave, Norwood, MA 02062-2643, USA
Tel: +1 800 564 8378 or +1 781 575 5000

European Headquarters
Coronation Road, High Wycombe, Bucks HP12 3SY, UK
Tel: +44 1494 464646

Instron Industrial Products
900 Liberty Street, Grove City, PA 16127, USA
Tel: +1 724 458 9610

Instron is a registered trademark of Illinois Tool Works Inc. (ITW). Other names, logos, icons and marks identifying Instron products and services referenced herein are trademarks of ITW and may not be used without the prior written permission of ITW. Other product and company names listed are trademarks or trade names of their respective companies. Copyright © 2017 Illinois Tool Works Inc. All rights reserved. All of the specifications shown in this document are subject to change without notice.